

KOMATSU®

PC500LC-8R

PC
500
LC

HORSEPOWER

Gross: 270 kW 362 HP / 1900 min⁻¹

Net: 257 kW 345 HP / 1900 min⁻¹

OPERATING WEIGHT

47700 – 50600 kg

BUCKET CAPACITY

2.70 – 4.00 m³



Photos may include optional equipment.

WALK-AROUND



Strengthened Arm

Strengthened Boom

Larger Bucket



Strengthened
Revolving
Frame with
Deck Guard

Full Roller Guards

PRODUCTIVITY, ECOLOGY & ECONOMY

- Higher Productivity with the Largest Bucket in Class
- Low Fuel Consumption by Total Control of the Engine, Hydraulic and Electronic System
- Low Emission Engine and Low Operation Noise
- Excellent Machine Stability
- Large Digging Force
- Two-mode Setting for Boom
- Variable Track Gauge (Optional)

COMFORT & SAFETY

- Large Comfortable Cab
- Automatic Air Conditioner (A/C) (Optional)
- Rear View Monitor System (Optional)

* Information and Communication Technology

ICT* & KOMTRAX

- Large Multi-lingual Liquid Crystal Display (LCD) Monitor
- Equipment Management Monitoring System
- KOMTRAX

MAINTENANCE & RELIABILITY

- Easy Maintenance
- Excellent Reliability and Durability

		PC500LC-8R
HORSEPOWER	Gross:	270 kW 362 HP / 1900 min ⁻¹
	Net:	257 kW 345 HP / 1900 min ⁻¹
OPERATING WEIGHT		47700 – 50600 kg
BUCKET CAPACITY		2.70 – 4.00 m ³

Photos may include optional equipment.

PRODUCTIVITY, ECOLOGY & ECONOMY

Higher Productivity with the Largest Bucket in Class

PC500LC-8R is equipped with the largest capacity bucket in Komatsu's 50 ton class. Less number of bucket passes is required to fill a dump truck, thus productivity is increased.

Bucket capacity

2.70 m³

3380 mm arm, material density up to 1.8 t/m³

Komatsu Technology

Komatsu develops and produces all major components, such as engines, electronics and hydraulic components, in house. With this "Komatsu Technology" and adding customer feedback, Komatsu is achieving great advancements in technology. To achieve both high levels of productivity and economical performance, Komatsu has developed the main components with a total control system. The result is a new generation of high performance and environment-friendly excavators.

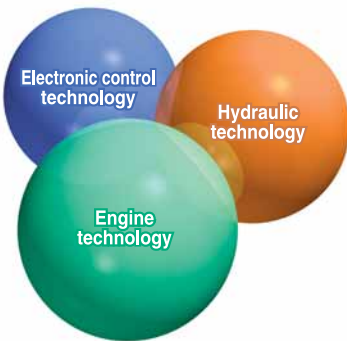

Idling Caution

To prevent unnecessary fuel consumption, an idling caution is displayed on the monitor, if the engine idles for 5 minutes or more.



TOTAL VEHICLE CONTROL

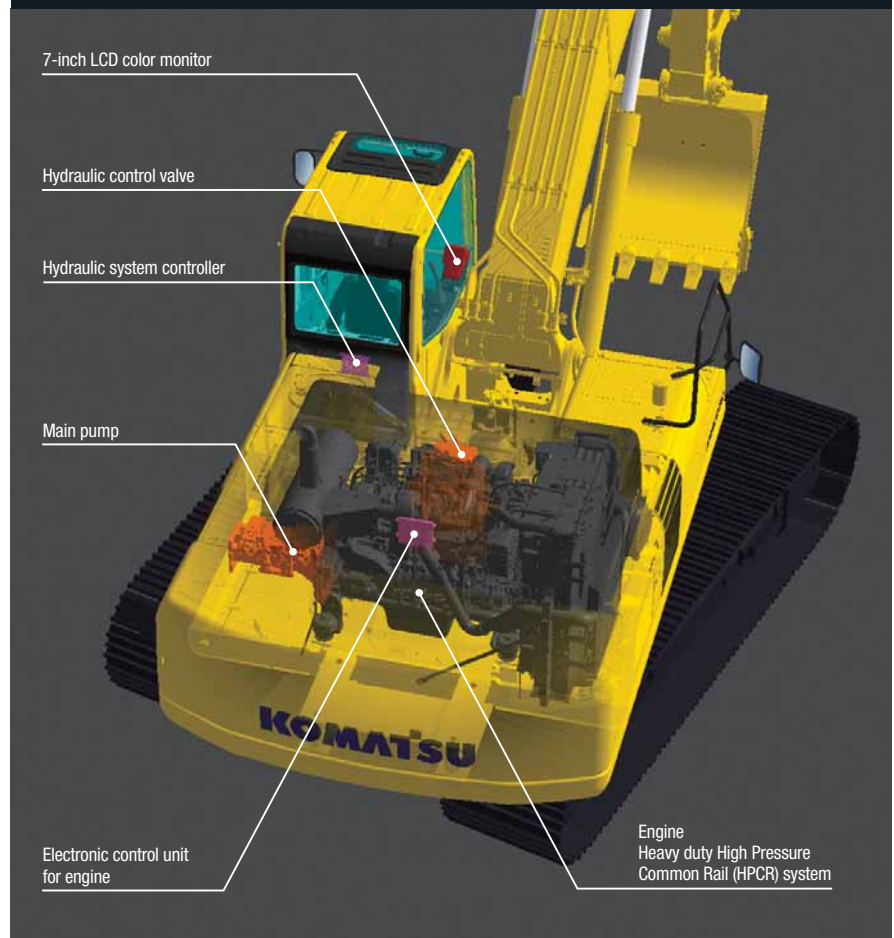

High Power Komatsu SAA6D125E-5 Engine

The PC500LC-8R gets its exceptional power and work capacity from a Komatsu SAA6D125E-5 engine. Output is 257 kW 345 HP, providing increased hydraulic power and improved fuel efficiency. The SAA6D125E-5 engine is U.S. EPA Tier 2 and EU Stage 2 emissions equivalent. The SAA6D125E-5 engine adopts the electronically controlled heavy duty High Pressure Common Rail (HPCR) fuel injection system.



Low Operation Noise

Enables a low noise operation using the low-noise engine and methods to cut noise at source. Ambient noise meets the EU Stage 2 noise regulation.

Excellent Machine Stability

Large counterweight offers superior machine stability and balance.

ECO Gauge that Assists Energy-saving Operations

Equipped with the ECO gauge that can be recognized at a glance on the right of the multi-function color monitor for environment-friendly energy-saving operations. Allows focus on operation in the green range with reduced CO₂ emissions and efficient fuel consumption.



ECO gauge

Working Modes Selectable

The PC500LC-8R excavator is equipped with five working modes (P, E, L, B and ATT mode). Each mode is designed to match engine speed and pump output to the application. This provides the flexibility to match equipment performance to the job at hand.



Working Mode	Application	Advantage
P	Power mode	<ul style="list-style-type: none"> • Maximum production/power • Fast cycle times
E	Economy mode	<ul style="list-style-type: none"> • Good cycle times • Better fuel economy
L	Lifting mode	<ul style="list-style-type: none"> • Suitable attachment speed • Lifting capacity is increased 7% by raising hydraulic pressure.
B	Breaker mode	<ul style="list-style-type: none"> • Optimum engine rpm, hydraulic flow
ATT	Attachment mode	<ul style="list-style-type: none"> • Optimum engine rpm, hydraulic flow, 2 way

Variable Track Gauge (Optional)

- Lateral stability is significantly improved when operating with the gauge extended.
- Lateral stability is increased by 30% (Compared with the fixed gauge version).
- With trackframes retracted, overall width complies with many local transportation regulations.



Large Digging Force

When press the left knob switch which is called the one-touch power max. switch and when it is kept pressed, this function temporarily increases digging force for 8.5 seconds of operation.

Maximum arm crowd force (ISO 6015):
 218 kN (22.2 t) ➔ **233 kN (23.8 t)** **7% UP**
 (With Power Max.)

Maximum bucket digging force (ISO 6015):
 259 kN (26.4 t) ➔ **278 kN (28.3 t)** **7% UP**
 (With Power Max.)

Measured with Power Max. function, 3380 mm arm and ISO 6015 rating.



One-touch power max. switch

Smooth Loading Operation

Two return hoses improve hydraulic performance. In the arm out function, a portion of the oil is returned directly to the tank providing smooth operation.

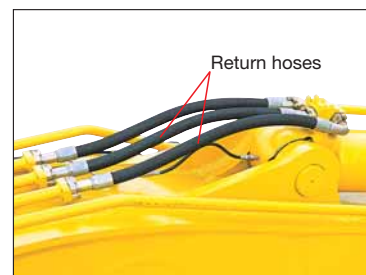

Return hoses

Two-mode Setting for Boom

Smooth mode provides easy operation for gathering blasted rock or scraping down operation. When maximum digging force is needed, switch to Power mode for more effective excavating.

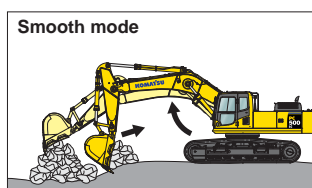

Boom floats upward, reducing lifting of machine front. This facilitates gathering blasted rock and scraping down operations.

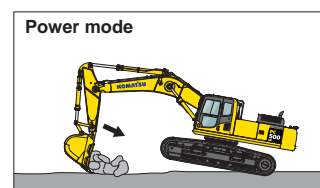

Boom pushing force is increased, ditch digging and box digging operation on hard ground are improved.

COMFORT



Low Cab Noise

The newly-designed cab is highly rigid and has excellent sound absorption ability. Thorough improvement of noise source reduction and use of low noise engine, hydraulic equipment, and air conditioner allows this machine to generate a low level of noise.

Low Vibration with Cab Damper Mounting

PC500LC-8R uses viscous damper mounting for cab that incorporates longer stroke and the addition of a spring. The new cab damper mounting combined with high rigidity deck aids vibration reduction at operator seat.

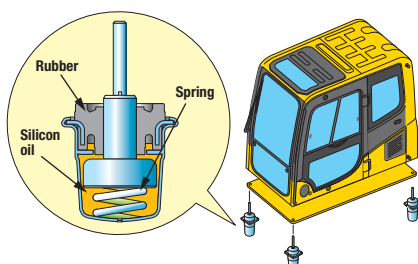

Wide Newly-designed Cab

Newly-designed wide spacious cab includes seat with reclining backrest. The seat height and longitudinal inclination are easily adjusted using a pull-up lever. You can set the appropriate operational posture of armrest together with the console. Reclining the seat further enables you to place it into the fully flat state with the headrest attached.



Pressurized Cab

Optional air conditioner (A/C), air filter and a higher internal air pressure minimize external dust from entering the cab.

Automatic Air Conditioner (A/C) (Optional)

Enables you to easily and precisely set cab atmosphere with the instruments on the large LCD. The bi-level control function keeps the operator's head and feet cool and warm respectively. This improved air flow function keeps the inside of the cab comfortable throughout the year. Defroster function keeps front glass clear.

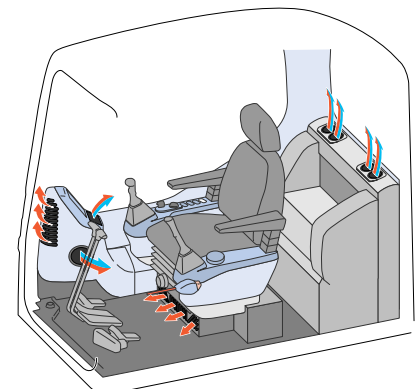

SAFETY

Operator's Cab

The machine is equipped with an operator's cab that conforms to OPG top guard level 1 (ISO 10262) for falling objects. The cab has high shock-absorption performance, featuring excellent durability and impact strength.



Slip-resistant Plates

Highly durable slip-resistant plates maintain superior traction performance for the long term.



Lock Lever

Locks the hydraulic pressure to prevent unintentional movement. Neutral start function allows machine to be started only in lock position.



Rear View Monitor System (Optional)

The operator can view the rear of the machine with a color monitor screen.



Rear view image on monitor

Pump/Engine Room Partition

Pump/engine room partition prevents oil from spraying onto the engine if a hydraulic hose should fail.



Thermal and Fan Guards

Thermal and fan guards are placed around high-temperature parts of the engine and fan drive.



Large Serrated Steps and Handrail

Large serrated steps



Large handrail



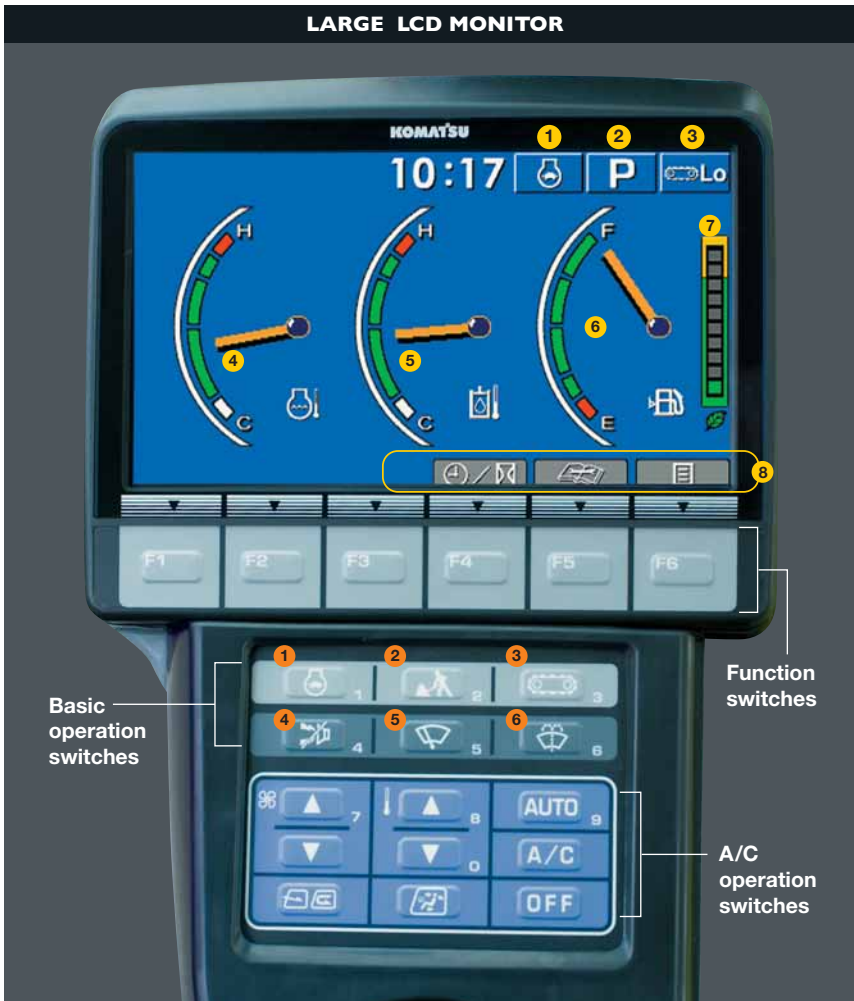

Large Multi-lingual LCD Monitor

A large user-friendly color monitor enables safe, accurate and smooth work. Improved screen visibility is achieved by the use of LCD that can easily be read at various angles and lighting conditions. Simple and easy to operate switches. Function keys facilitate multi-function operations. Displays data in 12 languages to globally support operators around the world.

Basic operation switches

Function switches

A/C operation switches

Indicators

- | | |
|----------------------------------|-----------------------------------|
| 1 Auto-decelerator | 5 Hydraulic oil temperature gauge |
| 2 Working mode | 6 Fuel gauge |
| 3 Travel speed | 7 ECO gauge |
| 4 Engine water temperature gauge | 8 Function switches menu |

Basic operation switches

- | | |
|-------------------------|---------------------|
| 1 Auto-decelerator | 4 Buzzer cancel |
| 2 Working mode selector | 5 Wiper |
| 3 Traveling selector | 6 Windshield washer |

Equipment Management Monitoring System

Monitor function

Controller monitors engine oil level, coolant temperature, battery charge and air clogging, etc. If controller finds any abnormality, it is displayed on the LCD.



Maintenance function

Monitor informs replacement time of oil and filters on the LCD when the replacement interval is reached.



Trouble data memory function

Monitor stores abnormalities for effective troubleshooting.



Assists Customer's Equipment Management and Contributes to Fuel Cost Cutting

Equipment Management Support

KOMTRAX terminal installed on your machine collects and sends information such as machine location, working record, machine conditions, etc. using wireless communication. You can review the KOMTRAX data remotely via the online application. KOMTRAX not only gives you the informations on your machine, but also the convenience of managing your fleet on the Web.

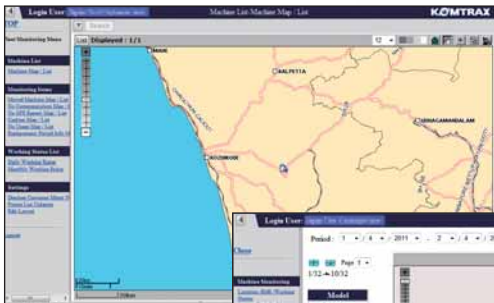

Location

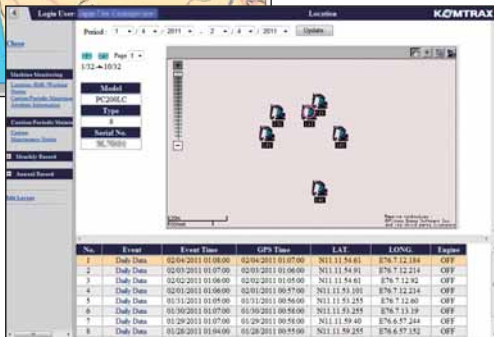

Movement generated position



Operation map



Monthly status summary

Energy-saving Operation Support Report

KOMTRAX can provide various useful information which includes the energy-saving operation support report created based on the operating information of your machine such as fuel consumption and idle time.

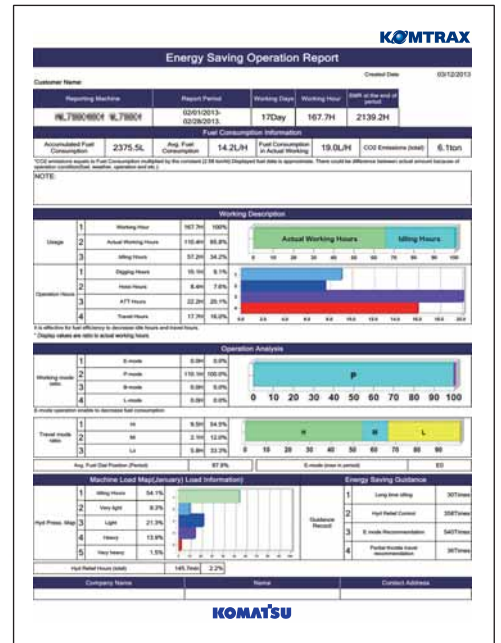

Image

MAINTENANCE

Easy Access to Engine Oil Filter and Fuel Drain Valve

Engine oil dipstick and fill, and fuel filter are mounted on same side to improve accessibility. Fuel drain valve are remotely mounted to improve accessibility.



Fuel drain valve

Electric Priming Pump

Bleeding air from fuel system is easily accomplished with the electric priming pump.

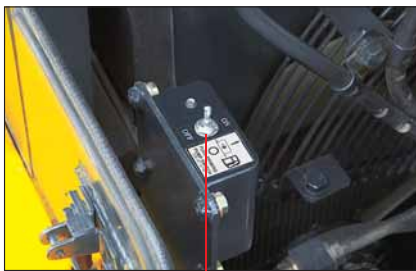

Electric priming pump switch

Easy Radiator Cleaning

Since radiator and oil cooler are arranged side-by-side, it is easy to clean, remove and install them.

Large Serrated Steps

On both right and left track frames are fixed with wider steps for easier maintenance.



Large Capacity Air Cleaner

Large capacity air cleaner is comparable to that of larger machines. The larger air cleaner can extend air cleaner life during long-term operation and prevents early clogging and resulting power decrease. Reliability is improved by a new seal design.



Long-life Oil, Filter

Uses high-performance filtering materials and long-life oil. Extends the oil and filter replacement interval.



Hydraulic oil filter

Engine oil & Engine oil filter	every 500 hours
Hydraulic oil	every 5000 hours
Hydraulic oil filter	every 1000 hours

Long Work Equipment Greasing Interval (Optional)

High quality bushings and resin shims are optionally available for work equipment pins excluding bucket, extending greasing interval to 500 hours.

Large Fuel Tank Capacity

Large fuel tank capacity extends operating hours before refueling. Fuel tank is treated for rust prevention and improved corrosion resistance.



RELIABILITY

Larger Undercarriage

PC500LC-8R employs undercarriage of PC450LC-8 one size larger with longer service life.

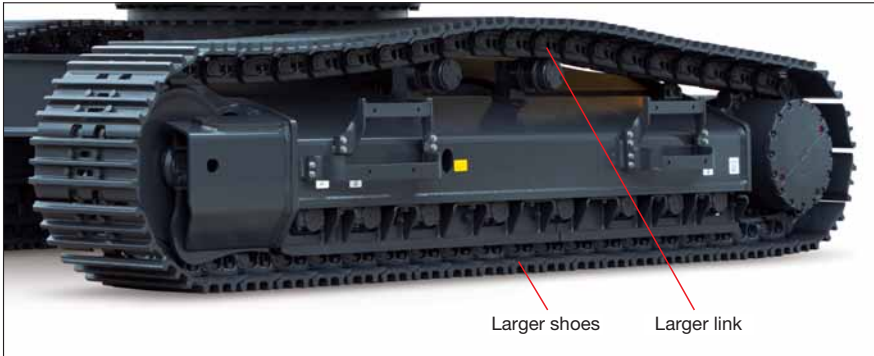

Large size undercarriage



Full roller guard (Optional)



Strengthened revolving frame under cover

High Rigidity Work Equipment

Boom and arms are constructed of thick plates of high tensile strength steel. In addition, these structures are designed with large cross-sectional areas and generous use of castings. The result is working attachments that exhibit long term durability and high resistance to bending and torsional stress.

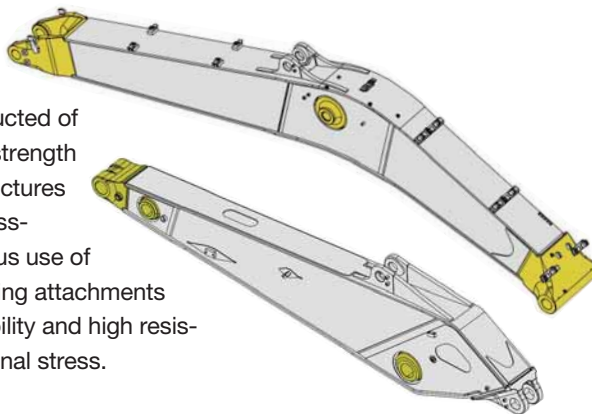

High Pressure In-line Filter

In-line filters are provided at outlet port (Pressure side) of each pump to protect hydraulic system contamination.



In-line filters

Equipped with Fuel Pre-filter (With Water Separator)

Removes water and contaminants in the fuel to prevent fuel problems.



Water Separator

Removes water from the fuel and improves the reliability of fuel systems.



Grease Sealed Track

PC500LC-8R uses grease sealed tracks for extended undercarriage life.

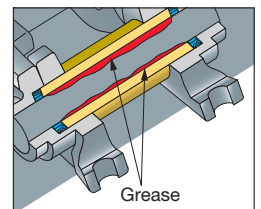

Larger Track Link with Strut

PC500LC-8R uses track links with strut, providing superb durability.

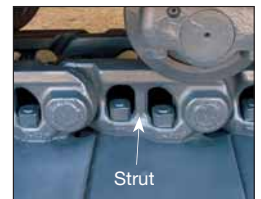

Sturdy Frame Structure

The revolving frame, center frame and undercarriage are designed by using the most advanced three-dimensional CAD and Finite Element Method (FEM) analysis technology.

Highly Reliable Electronic Devices

Exclusively designed electronic devices have passed severe testing.

- Controller
- Sensors
- Connectors
- Heat resistant wiring

Reliable Components

All of the major machine components, such as engine, hydraulic pumps, hydraulic motors and control valves are exclusively designed and manufactured by Komatsu.

BUCKET SELECTION

Larger Bucket Selection

Bucket Line-up

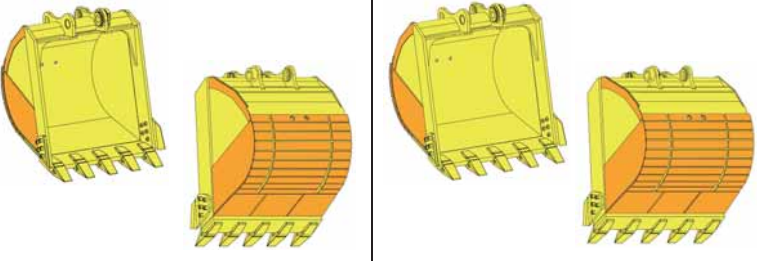
	7.06 m Boom	
	3.38 m Arm	
Capacity	2.70 m ³	3.10 m ³
Width*	1700 mm	1830 mm
Weight	2070 kg	2210 kg
Material Density	◎	○
Tooth Type	Horizontal	Horizontal
Shape		

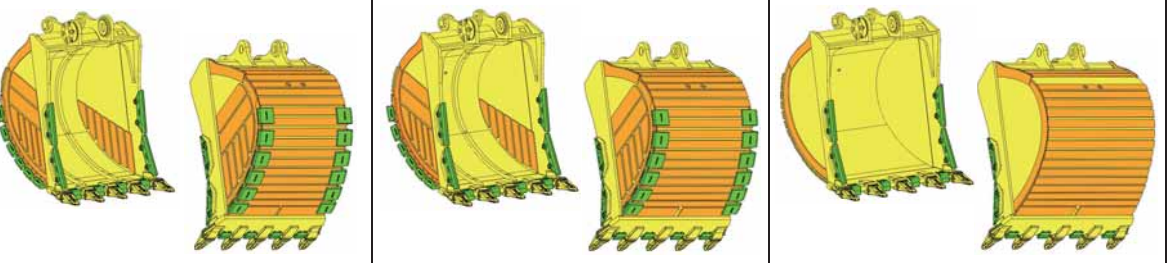
	6.67 m SE Boom		
	2.40 m Arm		
Capacity	3.10 m ³	3.50 m ³	4.00 m ³
Width*	1440 mm	1550 mm	1720 mm
Weight	3090 kg	3190 kg	2890 kg
Material Density	◎	○	○
Tooth Type	Horizontal / KMAX	Horizontal	Horizontal
Shape			

* With side shroud & tooth ◎: Material density up to 1.8 t/m³ ○: Material density up to 1.5 t/m³

Quarry Bucket and Work Equipment

PC500LC-8R bucket is designed exclusively for quarry use and is higher strength for wear. Various parts of work equipment are also strengthened.

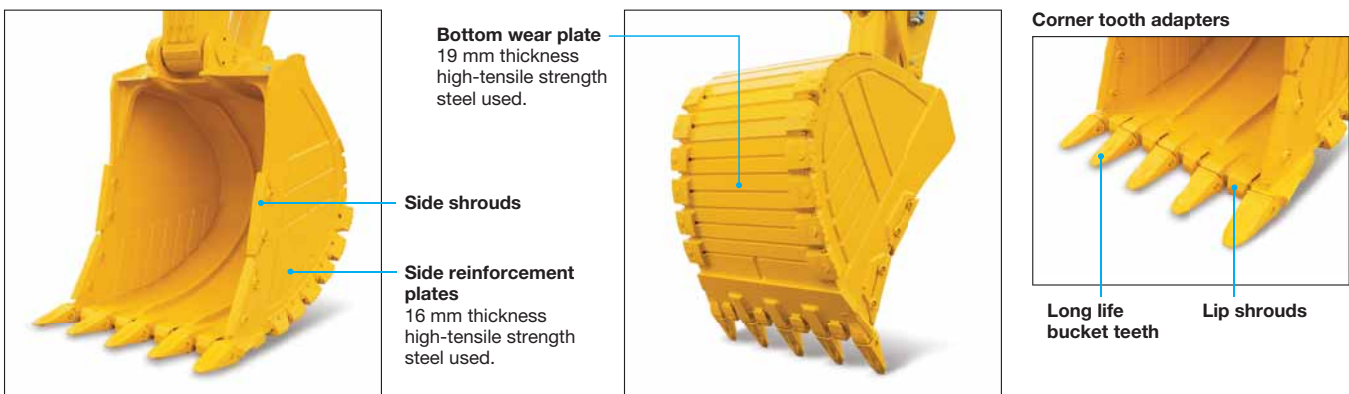

Feature of [PAB Tooth] (Pin And Bushing system Tooth)

- Able to fit on the bucket with horizontal pin type adapter
 - Easy change-out only with a ratchet wrench
 - Longer tooth life by easy rotation and turnover
 - Durable and reusable PAB pin with flat surface
- Limited to where horizontal pin type tooth is mainly used.

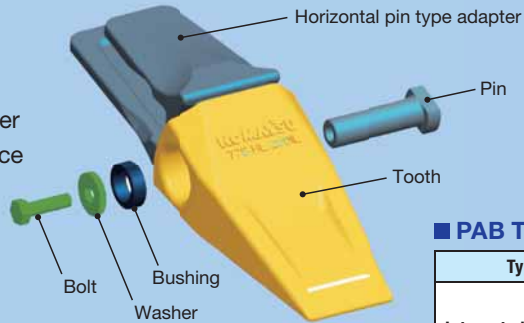

PAB Tooth Line-up

Type	Style
Integrated Long Life IL	
Heavy Standard HS	
Heavy Rock HR	



Set PAB tooth to horizontal pin type adapter



Insert exclusive pin to the adapter pin hole



Set bushing, washer and bolt and tighten by a ratchet wrench

Feature of KMAX Tooth System

- Better penetration and cycle times
- Unique reusable fastener
- Hardness throughout the tooth
- Less "throw away" waste
- Unique high strength design
- Fast tooth changeover



Tooth

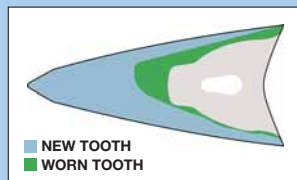

The KMAX RC style tooth shown here offers a consumption ratio of 60%.

Fastener

Simple, reusable fastener system saves time and money by unlocking with a simple 90-degree turn.



To lock, use the correct size socket, rotate the pin locking shaft 90-degree clock wise to finish the installation.



When removing the fastener, use the correct size socket to rotate the pin-locking shaft 90-degree counter-clockwise.

KMAX Tooth Line-up

Feature	Style
F Flare: Loose material for clean bottom and greater fill	
SYL Standard: General applications	
SD Chisel: General purpose tooth Designed for penetration	
RC Rock Chisel: Designed for penetration and long wear life	
T Tiger: Designed for good penetration with ribs for strength	
TV Tiger: Offers best penetration in tight material	
UT Twin Tiger: Offers longer life penetration for corners	
WT Twin Tiger: Designed for penetration for corners	

Some application may not have been available in your country or region. If you are interested in such application, please contact a KOMATSU office near you.

ATTACHMENT

Komatsu Genuine Attachment Tool

Komatsu-recommended attachment tools for hydraulic excavators
A wide range of attachment tools are provided to suit customers' specific applications.

Hydraulic breaker

The hydraulic breaker is an attachment tool used for crushing rock beds and paved surfaces, demolishing concrete structures, etc. The large gas chamber, ideal gas pressure ratio, and long-stroke piston deliver a powerful impact force. Since the breaker unit does not require an accumulator, the number of parts has been reduced, resulting in lower maintenance costs.



OPTIONS

- Cab front full height guard level 1 (ISO 10262)



- Cab front full height guard level 2 (ISO 10262)



- Additional front lights
- Rain visor



- Air pre-cleaner



- OPG top guard level 2 (ISO 10262)



- Strengthened track frame undercover



- Sun visor



- Seat, suspension



- Additional piping

- Fixed skylight and sun-shade



- Fixed one-piece laminated front window glass

The front window is fixed and uses laminated safety glass to prevent scattering of glass fragments when broken.



- Full roller guard



KOMATSU TOTAL SUPPORT



Komatsu Total Support

To keep your machine available and minimize operation cost when you need it, Komatsu Distributor is ready to provide variety of support before and after procuring the machine.

Fleet recommendation

Komatsu Distributor can study customer job site and provide the most optimum fleet recommendation with detailed information to meet all of your application needs when you are considering to buy new machines or to replace the existing ones from Komatsu.



Product support

Komatsu Distributor secure the certain quality of machine will be delivered.

Parts availability

Komatsu Distributor is available for emergency inquiry by the customers for genuine, quality guaranteed Komatsu parts.

Technical support

Komatsu product support service (Technical support) are designed to help customer. Komatsu Distributor offers a variety of effective services how much Komatsu is dedicated to the maintenance and support of Komatsu machine.

- Preventive Maintenance (PM) clinic
- Oil & Wear analysis program
- Undercarriage inspection service, etc.

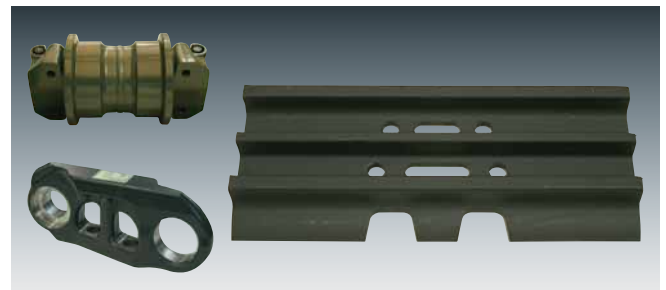

Repair & maintenance service

Komatsu Distributor offers quality repair service, periodical maintenance, and maintenance service to the customer, utilizing and promoting Komatsu developed programs.

Komatsu Reman (Remanufactured) components

Komatsu Reman products are the result of the implementation of the Komatsu global Reman policy which establishes and agrees to reduce the owning, operating and total Life Cycle Costs (LCC) to Komatsu's customer through prompt delivery, high quality and competitively priced in own remanufactured products (QDC).



SPECIFICATIONS



ENGINE

Model Komatsu SAA6D125E-5
 Type Water-cooled, 4-cycle, direct injection
 Aspiration Turbocharged, aftercooled
 Number of cylinders 6
 Bore 125 mm
 Stroke 150 mm
 Piston displacement 11.04 L
 Horsepower:
 SAE J1995 Gross 270 kW 362 HP
 ISO 9249 / SAE J1349 Net 257 kW 345 HP
 Rated rpm 1900 min⁻¹
 Fan drive method for radiator cooling Mechanical
 Governor All-speed control, electronic
 U.S. EPA Tier 2 and EU Stage 2 emissions equivalent.



HYDRAULICS

Type .. HydraulMind (Hydraulic Mechanical Intelligence New Design) system, closed-center system with load sensing valves and pressure compensated valves
 Number of selectable working modes 4
 Main pump:
 Type Variable displacement piston type
 Pumps for Boom, arm, bucket, swing, and travel circuits
 Maximum flow 690 L/min
 Supply for control circuit Self-reducing valve
 Hydraulic motors:
 Travel 2 x axial piston motor with parking brake
 Swing 1 x axial piston motor with swing holding brake
 Relief valve setting:
 Implement circuits 37.3 MPa 380 kg/cm²
 Travel circuit 37.3 MPa 380 kg/cm²
 Swing circuit 27.9 MPa 285 kg/cm²
 Pilot circuit 3.2 MPa 33 kg/cm²
 Hydraulic cylinders:
 (Number of cylinders – bore x stroke x rod diameter)
 Boom 2–160 mm x 1570 mm x 110 mm
 Arm
 Std 1–185 mm x 1985 mm x 130 mm
 SE 1–185 mm x 1820 mm x 120 mm
 Bucket
 Std 1–160 mm x 1270 mm x 110 mm
 SE 1–185 mm x 1160 mm x 120 mm



DRIVES AND BRAKES

Steering control Two levers with pedals
 Drive method Hydrostatic
 Maximum drawbar pull 330 kN 33700 kg
 Gradeability 70%, 35°
 Maximum travel speed: High 5.5 km/h
 (Auto-shift) Mid 4.2 km/h
 (Auto-shift) Low 3.0 km/h
 Service brake Hydraulic lock
 Parking brake Mechanical disc brake



SWING SYSTEM

Drive method Hydrostatic
 Swing reduction Planetary gear
 Swing circle lubrication Grease-bathed
 Service brake Hydraulic lock
 Holding brake/swing lock Mechanical disc brake
 Swing speed 9.1 min⁻¹



UNDERCARRIAGE

Center frame X-frame
 Track frame Box-section
 Seal of track Sealed track
 Track adjuster Hydraulic
 Number of shoes (Each side) 49
 Number of carrier rollers (Each side) 2
 Number of track rollers (Each side) 8



COOLANT AND LUBRICANT CAPACITY (REFILLING)

Fuel tank 650 L
 Coolant 36.0 L
 Engine 37.0 L
 Final drive (Each side) 10.5 L
 Swing drive 20.0 L
 Hydraulic tank 248 L



OPERATING WEIGHT (APPROXIMATE)

Operating weight including 7060 mm one-piece boom, 3380 mm arm, ISO 7451 heaped 2.70 m³ backhoe bucket, rated capacity of lubricants, coolant, full fuel tank, operator, and standard equipment.

Shoes	PC500LC-8R	
	Operating Weight	Ground Pressure
600 mm	47700 kg	82.6 kPa 0.84 kg/cm ²
700 mm	48200 kg	71.6 kPa 0.72 kg/cm ²

Operating weight including 6670 mm one-piece boom, 2400 mm arm, ISO 7451 heaped 3.10 m³ backhoe bucket, rated capacity of lubricants, coolant, full fuel tank, operator, and standard equipment.

Shoes	PC500LC-8R SE Spec.	
	Operating Weight	Ground Pressure
600 mm	48900 kg	84.7 kPa 0.86 kg/cm ²
700 mm	49400 kg	73.4 kPa 0.74 kg/cm ²



DIMENSIONS & WORKING RANGE

Model		PC500LC-8R	PC500LC-8R SE Spec.
Boom Length		7060 mm	6670 mm
Arm Length		3380 mm	2400 mm
A	Overall length	12035 mm	11625 mm
B	Length on ground	6640 mm	8070 mm
C	Overall height (To top of boom)*	3655 mm	3735 mm
D	Overall width	3560 mm	
E	Overall height (To top of cab)*	3315 mm	
F	Ground clearance, counterweight	1330 mm	
G	Ground clearance (Minimum)	565 mm	
H	Tail swing radius	3645 mm	
I	Track length on ground	4350 mm	
J	Track length	5385 mm	
K	Track gauge	2740 mm	
L	Width of crawler	3340 mm	
M	Shoe width	600 mm	
N	Grouser height	37 mm	
O	Machine cab height	2985 mm	
P	Machine cab width	3165 mm	
Q	Distance, swing center to rear end	3605 mm	
R	Max. digging height	11145 mm	9220 mm
S	Max. dumping height	7505 mm	6075 mm
T	Max. digging depth	7910 mm	6540 mm
U	Max. vertical wall digging depth	4580 mm	2000 mm
V	Max. digging depth of cut for 2440 mm level	7770 mm	6370 mm
W	Max. digging reach	12195 mm	10950 mm
X	Max. digging reach at ground level	11975 mm	10700 mm
Y	Min. swing radius	4820 mm	5090 mm
SAE 1179 Rating	Bucket digging force at power max.	243 kN 24800 kg	280 kN 28600 kg
	Arm crowd force at power max.	225 kN 22900 kg	261 kN 26600 kg
ISO 6015 Rating	Bucket digging force at power max.	278 kN 28300 kg	308 kN 31400 kg
	Arm crowd force at power max.	233 kN 23800 kg	269 kN 27400 kg

* Including grouser height

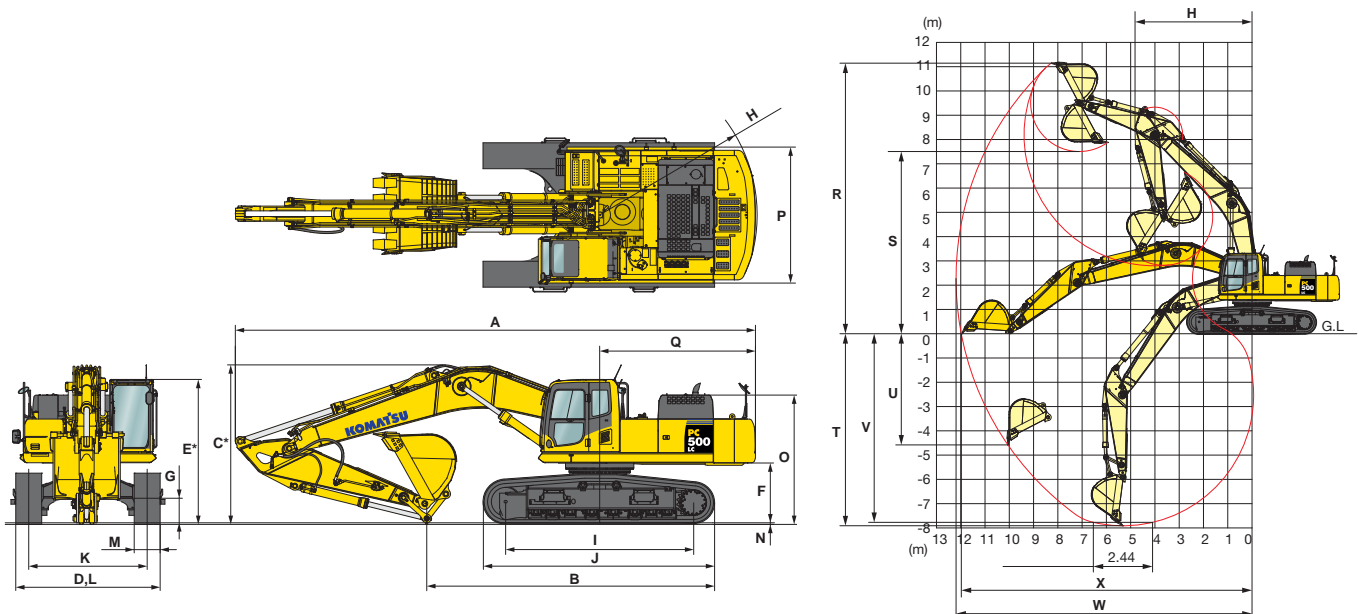



LIFTING CAPACITY WITH LIFTING MODE

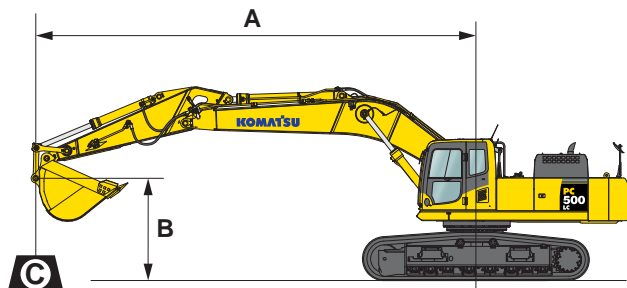

PC500LC-8R

- A: Reach from swing center
- B: Bucket hook height
- C: Lifting capacity
- Cf: Rating over front
- Cs: Rating over side
- ⊗: Rating at maximum reach

PC500LC-8R		Boom: 7060 mm		Arm: 3380 mm		Bucket: 2.70 m ³ ISO 7451 heaped		Shoe: 600 mm triple grouser					
B	A	⊗ MAX		9.0 m		7.5 m		6.0 m		4.5 m		3.0 m	
		Cf	Cs	Cf	Cs	Cf	Cs	Cf	Cs	Cf	Cs	Cf	Cs
7.5 m		*5820 kg	*5820 kg										
6.0 m		*5830 kg	5820 kg	*8680 kg	6810 kg	*9450 kg	*9450 kg						
4.5 m		*6040 kg	5180 kg	*9100 kg	6620 kg	*10430 kg	9210 kg	*12710 kg	*12710 kg				
3.0 m		*6460 kg	4840 kg	*9680 kg	6360 kg	*11600 kg	8730 kg	*14820 kg	12590 kg	*20870 kg	19790 kg		
1.5 m		*7120 kg	4720 kg	*10240 kg	6110 kg	*12530 kg	8320 kg	*16460 kg	11850 kg	*17210 kg	*17210 kg		
0 m		*8140 kg	4820 kg	10170 kg	5920 kg	*13040 kg	8020 kg	*17080 kg	11380 kg	*17750 kg	*17750 kg		
-1.5 m		8980 kg	5180 kg	10070 kg	5830 kg	*12980 kg	7850 kg	*16880 kg	11170 kg	*22680 kg	17840 kg	*10680 kg	*10680 kg
-3.0 m		*9110 kg	5950 kg	*9150 kg	5880 kg	*12140 kg	7830 kg	*15750 kg	11170 kg	*20610 kg	18020 kg	*21910 kg	*21910 kg
-4.5 m		*8890 kg	7480 kg			*10020 kg	7990 kg	*13440 kg	11390 kg	*17330 kg	*17330 kg	*21890 kg	*21890 kg
-6.0 m		*7750 kg	*7750 kg					*8980 kg	*8980 kg	*12080 kg	*12080 kg		

* Load is limited by hydraulic capacity rather than tipping. Ratings are based on SAE J1097. Rated loads do not exceed 87% of hydraulic lift capacity or 75% of tipping load.

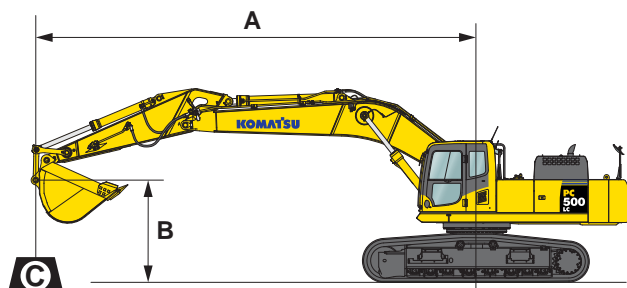

PC500LC-8R SE Spec.

- A: Reach from swing center
- B: Bucket hook height
- C: Lifting capacity
- Cf: Rating over front
- Cs: Rating over side
- ⊗: Rating at maximum reach

PC500LC-8R		Boom: 6670 mm		Arm: 2400 mm		Me bucket: 3.10 m ³ ISO 7451 heaped		Shoe: 600 mm triple grouser					
B	A	⊗ MAX		9.0 m		7.5 m		6.0 m		4.5 m		3.0 m	
		Cf	Cs	Cf	Cs	Cf	Cs	Cf	Cs	Cf	Cs	Cf	Cs
7.5 m		*10130 kg	8860 kg										
6.0 m		*9790 kg	6980 kg			*10290 kg	8630 kg	*11980 kg	*11980 kg				
4.5 m		*9690 kg	6000 kg			*11000 kg	8300 kg	*13830 kg	12560 kg	*18820 kg	*18820 kg		
3.0 m		*9710 kg	5520 kg	*9710 kg	5560 kg	*11840 kg	7900 kg	*15520 kg	11830 kg				
1.5 m		9610 kg	5390 kg	9660 kg	5400 kg	*12510 kg	7700 kg	*16500 kg	11240 kg				
0 m		*9880 kg	5620 kg	*9460 kg	5300 kg	*12520 kg	7490 kg	*16570 kg	10930 kg	*21930 kg	16850 kg		
-1.5 m		*9870 kg	6290 kg			*11700 kg	7430 kg	*15550 kg	10850 kg	*20170 kg	17830 kg	*19500 kg	*19500 kg
-3.0 m		*9550 kg	7760 kg			*9090 kg	7470 kg	*13260 kg	10990 kg	*16990 kg	*16990 kg	*18580 kg	*18580 kg
-4.5 m		*8220 kg	*8220 kg					*8640 kg	*8640 kg	*11870 kg	*11870 kg		
-6.0 m													

* Load is limited by hydraulic capacity rather than tipping. Ratings are based on SAE J1097. Rated loads do not exceed 87% of hydraulic lift capacity or 75% of tipping load.



STANDARD EQUIPMENT

ENGINE:

- Automatic engine warm-up system
- Dry type air cleaner, double element
- Electric priming pump
- Engine, Komatsu SAA6D125E-5
- Engine overheat prevention system
- Fuel pre-filter (With water separator)
- Radiator and oil cooler dust proof net
- Water separator

ELECTRICAL SYSTEM:

- Alternator, 24 V/50 A
- Auto-decelerator
- Batteries, 2 X 12 V/110 Ah
- Working light, 2 (Boom and RH)

HYDRAULIC SYSTEM:

- Boom holding valve
- Long lubricating intervals for implement bushings
- Power maximizing system
- Pressure Proportional Control (PPC) hydraulic control system
- Two-mode setting for boom
- Working mode selection system

GUARDS AND COVERS:

- Fan guard structure
- Track roller guards (Full length)

UNDERCARRIAGE:

- Hydraulic track adjusters (Each side)
- Track roller
 - 8 each side
- Track shoe
 - 600 mm triple grouser

OPERATOR ENVIRONMENT:

- Large multi-lingual LCD monitor
- Rear view mirrors (RH and LH)
- Seat belt, retractable

OTHER EQUIPMENT:

- Counterweight, 10500 kg
- Electric horn
- Rear reflector
- Slip-resistant plates
- Travel alarm



OPTIONAL EQUIPMENT

ELECTRICAL SYSTEM:

- Alternator, 24 V/60 A
- Batteries, 2 X 12 V/140 Ah
- Working lights (2 on cab)

HYDRAULIC SYSTEM:

- Attachment piping
- Service valve

UNDERCARRIAGE:

- Shoes, triple grouser shoes
 - 700 mm
- Track frame undercover
- Variable track gauge

OPERATOR ENVIRONMENT:

- A/C with defroster
- Bolt-on top guard, OPG top guard level 2 (ISO 10262)
- Cab accessories
 - Rain visor
 - Sun visor
- Cab front guard
 - Full height guard, OPG level 1 (ISO 10262)
 - Full height guard, OPG level 2 (ISO 10262)
 - Half height guard
- Heater with defroster
- Rear view mirror (Rear and sidewise)
- Rear view monitor system
- Seat, suspension
- Seat, suspension with heater

WORK EQUIPMENT:

- Arms
 - PC500LC-8R
 - 3380 mm arm assembly
 - PC500LC-8R SE spec.
 - 2400 mm SE arm assembly
- Booms (Backhoe)
 - PC500LC-8R
 - 7060 mm boom assembly
 - PC500LC-8R SE spec.
 - 6670 mm SE boom assembly

OTHER EQUIPMENT:

- Fuel refill pump
- Pre-cleaner