

# PLATFORM BASKET

SELF-PROPELLED AERIAL WORK PLATFORMS

...Made simple



## SPIDER 18.90

**Lightweight and easily  
Transportable on trailers.**

**Articulated boom with fly-jib  
for greater versatility**

**Simple and intuitive controls  
and safety devices. Easy to  
use & easy to rent.**

**Excellent weight/horizontal  
outreach ratio**

**Full working height with  
200kg of basket capacity**

**Automatic outreach  
limiter**

**Variable track width for  
extra stability while  
Travelling**

**Basket rotation 70+70 deg  
on request**

**Easy maintenance**

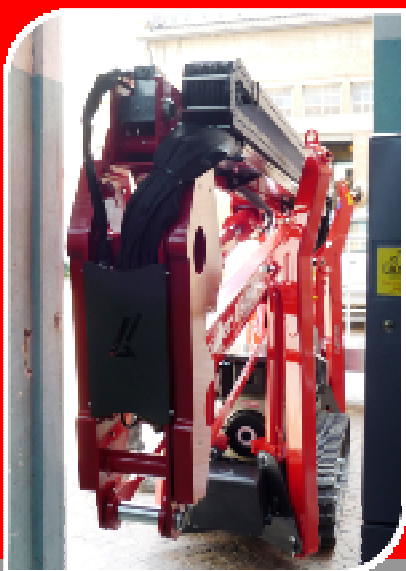

**TRACKED SELF-PROPELLED PLATFORMS**

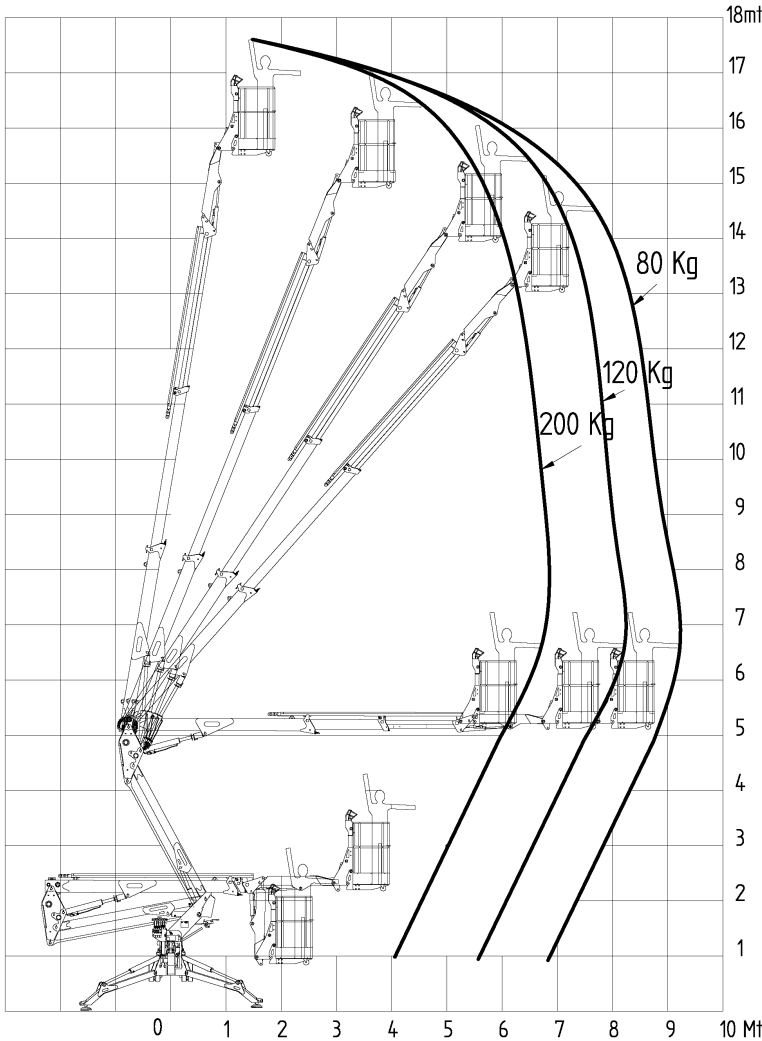

Technical data	
Max working height	m 17,70
Working height to the basket floor	m 15,70
Max side outreach (80kg)	m 9,30
Turret rotation	Deg. 360°
Cage dimensions (Aluminium)	L x W m 1,20x0,66
Rotation cage (Optional)	Deg. 70+70
Max cage capacity (2 people)	kg 200
Lenght in stowed position (Without cage)	mm 4910 4250
Minimum width in stowed position	mm 780
Minimum height in stowed position	mm 1950
Stabilization foot-print	m 3,70x3,10
Max driving speed	Km/h 1,50
Max gradeability	deg 27° (51%)
Max side gradeability	deg 14° (25%)
Total weight	kg 2300*
Surface load in the driving position (extended tracks)	N/cm2 1,70
Surface load in working position.	KN/m2 2,00
Max load on stabilizer	KN 15
GX390 Honda Petrol or L100N—Yanmar Diesel	Hp/RPM 11/3600 10/3200

STANDARD FEATURES:
Emergency hand pump
Quick and easily removeable cage
Hour meter
Stabilisers/booms interlocking
Automatic safe working device
Black rubber tracks
110/220 Vac Electric motor for indoor use
Variable tracks width
Complying with EN280 - AS1418.10 - B354-4
OPTIONALS:
Non-marking tracks
Emergency descent electric power-pack 12 VDC
110/220 Vac outlet in the cage
Cage anti-collision kit
Air & water outlet in the cage
Customized color.
Drive & Stabilization by radio remote control.
Electronic planarity sensor
Increased size of foot-plates (330mm diam)
Cage rotation 70+70 deg

\* May differs due to the configuration

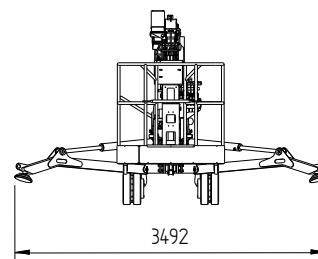
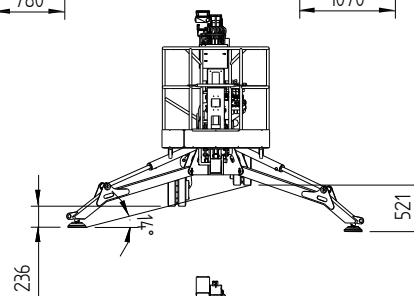
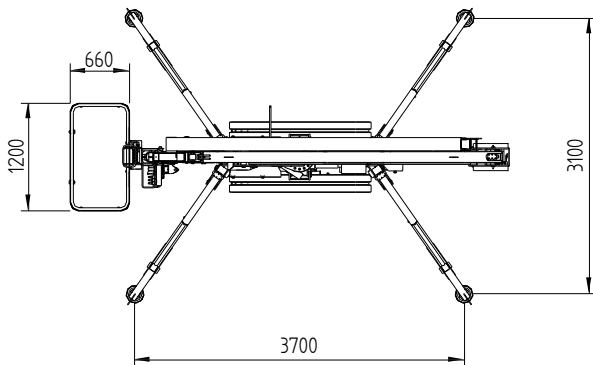
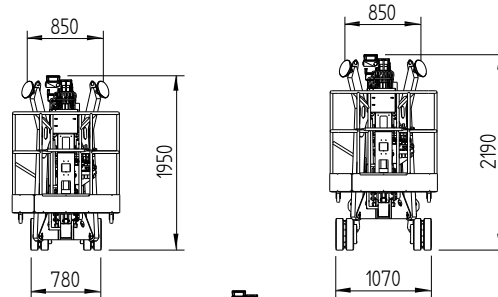
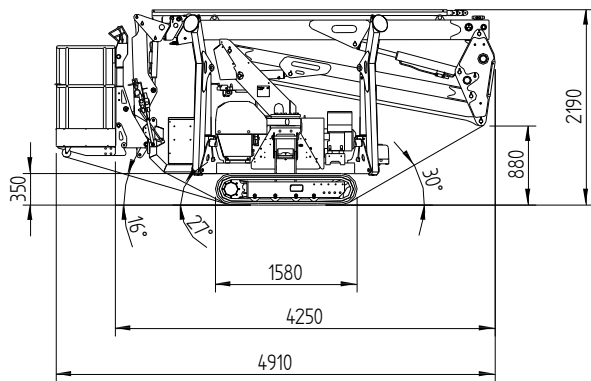

DATA, DIMENSIONS AND FEATURES ARE INDICATIVE AND NOT BINDING. Rev.2—06/04/2010