

**SUNWAY®**

**R15/18PS**

REACH TRUCK  
WAREHOUSE SERIES



**NEW ENERGY FORKLIFT LEADER**

BYD Efficient Lithium-Ion Electric Forklift

# STANDARD FEATURES

## Safety

- |   |   |  |
|---|---|--|
| <ul style="list-style-type: none"> <li>• Electric braking system</li> <li>• Slope protection</li> <li>• Turning speed limit</li> <li>• Programmable automatic speed limit</li> <li>• Battery sleep</li> </ul> | <ul style="list-style-type: none"> <li>• High loading position speed protection</li> <li>• Power-off protection</li> <li>• Charger protection</li> <li>• Reversing alarm</li> <li>• Front-rear movement buffer</li> </ul> | <ul style="list-style-type: none"> <li>• Cylinder lifting end buffer</li> <li>• Cylinder lowering speed limit</li> <li>• Operator Presence Sensor</li> <li>• LED headlights</li> </ul> |
|---|---|--|

## Performance

- |  |  |  |
|--|--|--|
| <ul style="list-style-type: none"> <li>• Iron-phosphate battery</li> <li>• AC drive system</li> <li>• AC hydraulic lift system</li> <li>• Small turning radius</li> <li>• Battery rapid charging &amp; opportunity charging</li> <li>• Programmable performance</li> </ul> | <ul style="list-style-type: none"> <li>• Digital (LCD) multifunction display               <ul style="list-style-type: none"> <li>– Time &amp; date</li> <li>– OPS time accumulator</li> <li>– Battery capacity indicator</li> <li>– Over-discharge warning (lift interrupt)</li> <li>– Parking brake indicator</li> </ul> </li> </ul> | <ul style="list-style-type: none"> <li>– Direction indicator</li> <li>– Maintenance indicator</li> <li>– Height &amp; weight indicator</li> <li>• Error code alarm</li> <li>• Built-in analyzer</li> <li>• Self-diagnostics</li> </ul> |
|--|--|--|

## Operability & Ergonomics

- |   |  |   |
|---|--|---|
| <ul style="list-style-type: none"> <li>• Strategically configured instrument</li> <li>• Electric directional shift control</li> </ul> | <ul style="list-style-type: none"> <li>• Forward/backward shifting</li> <li>• Dash-mounted USB port</li> </ul> | <ul style="list-style-type: none"> <li>• Heavy-duty slip-resistant floor mat</li> </ul> |
|---|--|---|

## Serviceability

- |  |  |   |
|--|--|---|
| <ul style="list-style-type: none"> <li>• AC drive motor (no brushes or commutator)</li> <li>• AC hydraulic motor (no brushes or commutator)</li> <li>• Charging port analyzing connection</li> </ul> | <ul style="list-style-type: none"> <li>• Easy-access no-tools floorboard</li> <li>• Maintenance - free sealing battery case</li> <li>• Easy-lift battery hood</li> </ul> | <ul style="list-style-type: none"> <li>• Hydraulic fluid level check</li> <li>• Easy-access controllers</li> <li>• CAN-bus controller wiring</li> </ul> |
|--|--|---|

# OPTIONAL EQUIPMENT

## Load Handling (Wide visible mast)

- |  |   |  |
|--|---|--|
| <ul style="list-style-type: none"> <li>• Standard lift 2-stage mast (Duplex standard)</li> <li>• Full free-lift 3-stage 3-cylinder mast (Triplex FFL)</li> </ul> | <ul style="list-style-type: none"> <li>• Lifting buffer</li> <li>• Customized fork</li> </ul> | <ul style="list-style-type: none"> <li>• Customized load backrest</li> <li>• Customized fork sleeve</li> </ul> |
|--|---|--|

## Load Handling (Hose & Valve Assembly)

- |   |  |   |
|---|--|---|
| <ul style="list-style-type: none"> <li>• 3-way valve achieve 4 functions</li> </ul> | <ul style="list-style-type: none"> <li>• Cascade hang-on side shifter</li> </ul> | <ul style="list-style-type: none"> <li>• Forward/backward shifting</li> </ul> |
|---|--|---|

## Lights & Indicators

- |  |   |  |
|--|---|--|
| <ul style="list-style-type: none"> <li>• Front &amp; rear headlight</li> <li>• Strobe light</li> </ul> | <ul style="list-style-type: none"> <li>• LED Distance Warning spot Light</li> <li>• LED Distance Warning laser Light</li> </ul> | <ul style="list-style-type: none"> <li>• Back up buzzer</li> </ul> |
|--|---|--|

## Body

- |   |  |  |
|---|--|--|
| <ul style="list-style-type: none"> <li>• Fork camera</li> <li>• Lifting height display</li> <li>• Hydraulic weighing &amp; display</li> </ul> | <ul style="list-style-type: none"> <li>• Panoramic rearview mirror</li> <li>• Overload protection</li> </ul> | <ul style="list-style-type: none"> <li>• Fan</li> <li>• Special key</li> </ul> |
|---|--|--|

# TECHNICAL SPECIFICATIONS

Characteristic	Manufacturer		BYD	BYD	
	Model		R15PS	R18PS	
	Power type		Electric	Electric	
	Operation type		Stand-on	Stand-on	
	Load capacity	Q	kg	1500	1800
	Load centre	c	mm	500	500
	Axle centre to force face ( mast extended)	x	mm	200	200
	Wheel base	y	mm	1350	1500
	Mast reach distance		mm	520	670
Weights	Service weight(including battery)		kg	2375	2515
	Axle load, mast extended without load,drive/support arm wheel		kg	1295/1080	1405/1100
	Axle load, mast retracted without load,drive/support arm wheel		kg	1550/825	1700/815
	Axle load, mast extended without load,drive/support arm wheel		kg	515/3360	565/3750
	Axle load, mast retracted without load,drive/support arm wheel		kg	1350/2525	1665/2650
Wheels	Wheel type			Polyurethane	Polyurethane
	Wheel size, driving			Φ313×125	Φ313×125
	Tyre size, rear(load)			Φ254×114	Φ254×114
	Wheel size, front(caster)			Φ150×80	Φ150×80
	Wheels, number front/Rear (x = driven)			1x+1/2	1x+1/2
	Track width, front	b11	mm	980	980
	Track width, rear		mm	650	650
Dimensions	Fork carriage tilt, forward/backward	α/β	(°)	3/5	3/5
	Height of mast, lowered	h1	mm	2025	2025
	Free lift	h2	mm	125	125
	Lift	h3	mm	3000	3000
	Height of mast, extended	h4	mm	4220	4220
	Height of overhead guard (cabin)	h6	mm	2250	2250
	Height of reach legs	h8	mm	275	275
	Overall length	l1	mm	2175	2175
	Length to fork face	l2	mm	1255	1255
	Overall width	b1	mm	1090	1090
	Fork dimensions	s/e/l	mm	40/100/920	40/100/920
	Fork carriage to ISO 2328, class/type A, B			2A	2A
	Width of fork carriage	b3	mm	730	730
	Width across forks(min/max)	b5	mm	200/680	200/680
	Width between reach legs	b4	mm	750	750
	Mast reach travel	l4	mm	520	670
	Ground clearance, below mast	m1	mm	73	73
	Ground clearance, centre of wheelbase	m2	mm	80	80
	Aisle width with pallet 1000 x 1200 across forks	Ast	mm	2707	2751
	Aisle width with pallet 800 x 1200 along forks	Ast	mm	2767	2782
Turning radius	Wa	mm	1600	1750	
Length of chassis	l7	mm	1720	1870	
Performance	Travel speed, with/without load		km/h	10.5/10.5	10.5/10.5
	Lifting speed, with/without load		mm/s	320/500	320/500
	Lowering speed, with/without load		mm/s	500/500	500/500
	Maximum climbing ability, with/without load		%	10/15	10/15
	Service brake			Electro-magnetic	Electro-magnetic
Drive	Drive motor, 60 minute rating		kw	5.8	5.8
	Lift motor, rating at S3 15%		kw	8.8	8.8
	Battery voltage/rated capacity		V/Ah	48(210/420)	48(210/420)
	Battery weight		kg	365	365
Others	Type of drive control			AC	AC
	Operating pressure for attachments		bar	210	210
	Noise level at operator's ear		dB(A)	≤75	≤75

\*BYD reserves the right to alter and modify the design, features and technical parameters of its products at any given time and without pre-advise, as products are subject to ongoing and continuous development.

# MAST SPECIFICATIONS

- h3** Lifting Height (mm)    **h2** Full Free Lift Height (mm)    **h1** Height, Mast Fully Lowered (mm)
- h4** Height, Mast Fully Extended (mm)    **α** Tilt Forward    **β** Tilt Backward

Mast Specifications	h3	h2	h1	h4	α	β	Residual Capacity (kg) @500mm	
							R15PS	R18PS
2-stage standard Mast	3000	125	2025	4220	3°	5°	1500	1800
	3300	125	2175	4520	3°	5°	1500	1800
	3500	125	2275	4720	3°	5°	1500	1800
	4000	125	2575	5220	3°	5°	1450	1800
	4500	125	2825	5720	3°	5°	1350	1650
	5000	125	3125	6220	3°	5°	1150	1500
3-stage with single FFL Mast	4000	680	1900	5220	3°	5°	1450	1800
	4500	830	2050	5720	3°	5°	1350	1650
	4800	930	2150	6020	3°	5°	1300	1580
	5000	980	2200	6220	3°	5°	1150	1500
	5500	1180	2400	6720	3°	5°	1050	1250
	6000	1450	2670	7220	3°	5°	950	1050

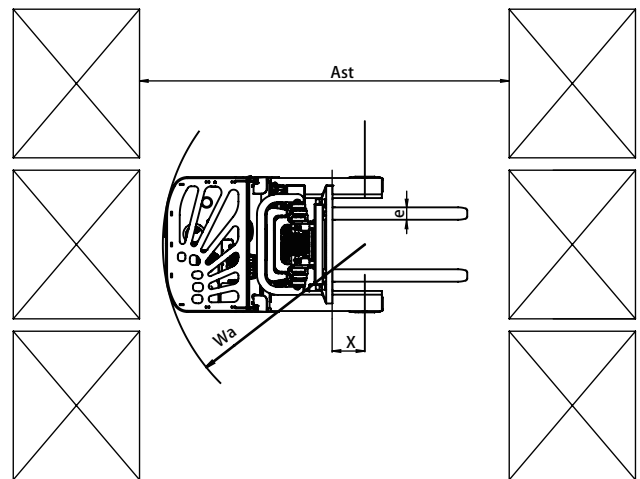
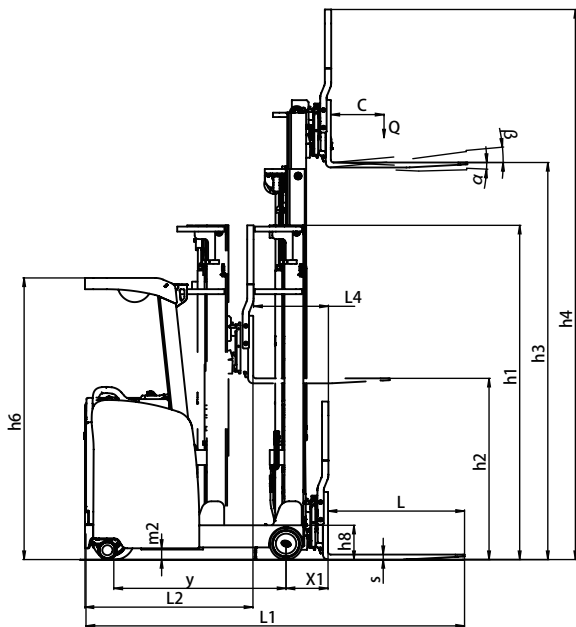

BYD Forklift production site is certified:  
**ISO 9001 ISO 40001 OHSAS 18001**



**SUNWAY MARKETING (S) PTE LTD**  
 A member of Sunway Group



11 Gul Street 4 Singapore 629240  
 Tel: +65 6631 9968

19 Senoko South Road Singapore 758078  
 Tel: +65 6758 5454 Fax: +65 6257 8759

**Mobile Service Hotline: +65 8622 8181**