

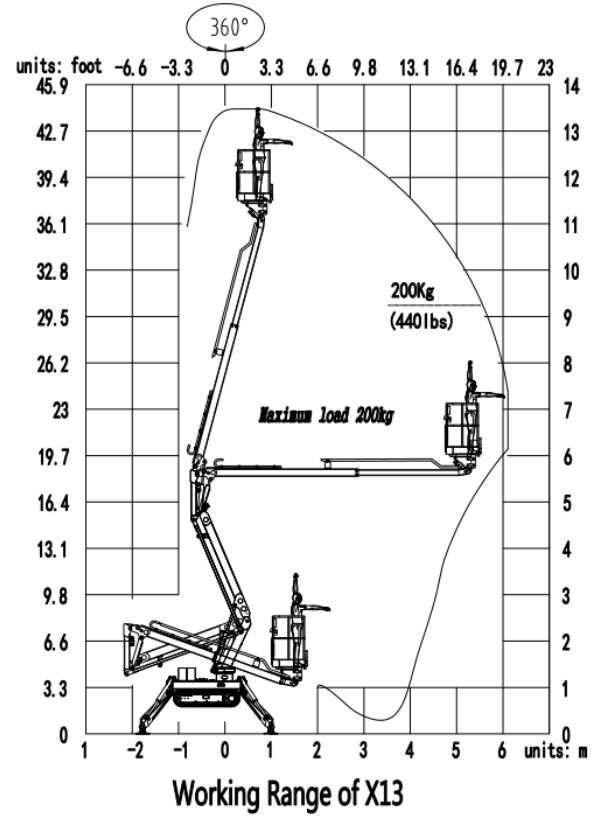

X13

Standard Parameters

Model	X13	GX44
Max. work height m	13.4	44'
Max. platform height m	11.4	37'
Load capacity	200KG	440lb
Lateral Outreach m	6.2m	20'
Turntable rotation	360° non-continuous	
Size of platform	0.8*0.7*1.1m	31" x 28" x 43"
Overall stowed length (without basket)	4.13m/3.85m	163"/152"
Overall stowed width (without basket)	0.87 m/0.79m	34"/31"
Overall stowed height	1.97m	78"
Total weight	1800kg	3968lb
Travelling speed km/h	0-2.5	
Climbing ability	17°	
Work slope (Side)	18°	
Power Options	110V/220V AC power/Fuel engine/Batteries	



Technical data

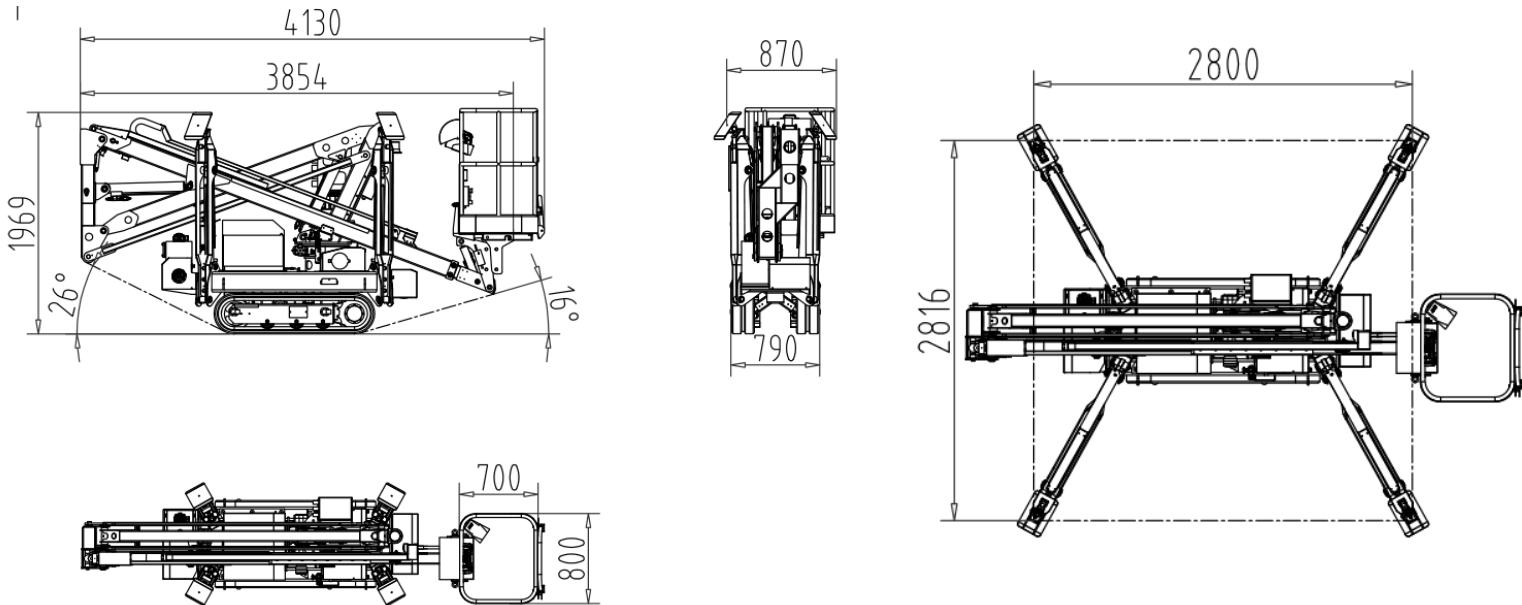

Standard Features

- ▶ Compact design for indoor and outdoor use
- ▶ Detachable Basket
- ▶ Self-leveling platform
- ▶ Automatic Outriggers leveling
- ▶ 360° non-continuous turntable rotation
- ▶ Hydraulically arms and outrigger interlocks
- ▶ Made of high tensile steel
- ▶ Reach standards of ISO, CE and ANSI

