

Capacity chart (2-stage free view mast)

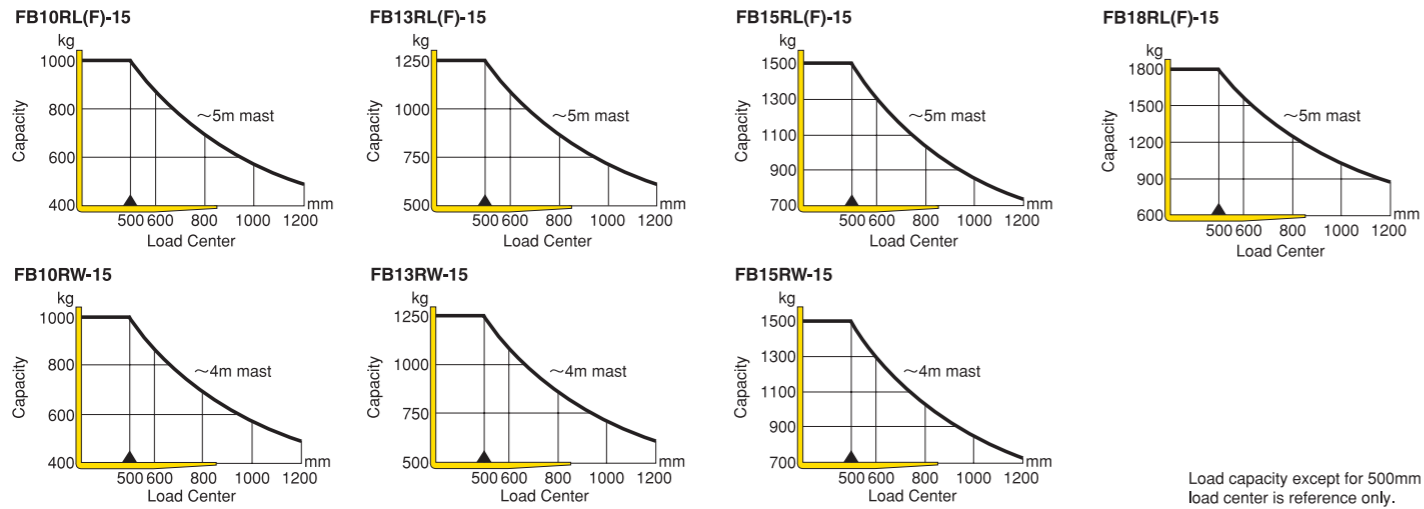

Attachments / Options

Attachments

- Integral Side Sifter



- Hinged Fork
- Roll Clamp
- Rotating Fork
- Fork Positioner

Options

Bright and energy-saving lamp

- LED Head Lights



- LED Yellow Strobe Light



- Load Checker



It indicates a rough load value in multiples of 10kg.

- Laser Lift Height Sensor



Newly made available for cold-storage models*
Guiding laser beam indicates the actual height of the fork accurately, allowing the operator to insert the fork into the pallet safely and quickly.
* Available for limited masts of FB15RLF/18RLF

KOMATSU

1.0-1.8 ton

BATTERY **REACH TRUCKS**

www.Komatsu.com

Printed in Japan 0312-1-03 IP.KAI

KOMATSU®

GET YOUR FREE QUOTE

www.scantruck.com.sg
Hotline: (+65)-6305-6600
Email: marketing@scantruck.com.sg

SCANTRUCK



Form No. BR-1.0-1.8tReach-15

Materials and specifications are subject to change without notice
KOMATSU is a trademark of Komatsu Ltd. Japan



Photo may include optional equipment

Komatsu new reach trucks satisfy both outstanding drive performance and considerable reduction in operating cost



Excellent stability, safety and drive performance

Komatsu center drive system is the key to safe and secure operation

High stability in cargo handling is ensured thanks to a design that enables receiving the load by the center drive wheel. With larger load distribution to the rear wheels, the machine demonstrates excellent longitudinal stability both in reach-in and reach-out operations. The residual capacity is not reduced up to a lifting height of 5 m, load swing is cut considerably. This system offers an outstanding high lifting performance. The machine performs jobs energetically with a compact body and reduces cycle time drastically. It offers by far the best operating capacity.

*Only RL type

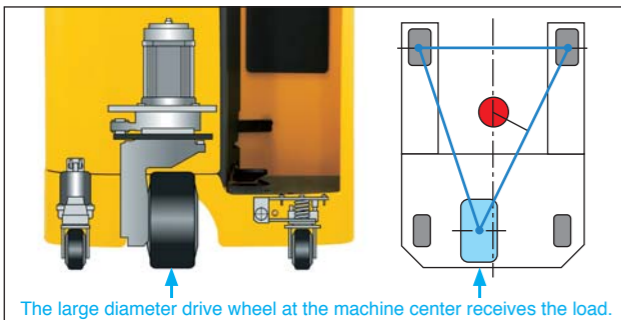
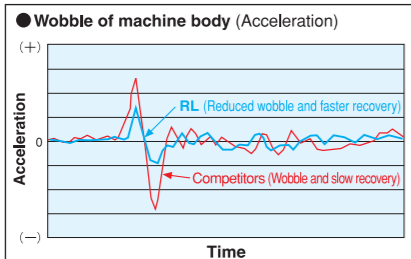

The new mast has the best rigidity in its class

The outer mast is same profile as the 3.0 ton trucks series, substantially increased stability during cargo handling. The sturdy mast decreases load swing dramatically. Since you don't have to wait for the load swing to dissipate, you can reduce the cycle time drastically.

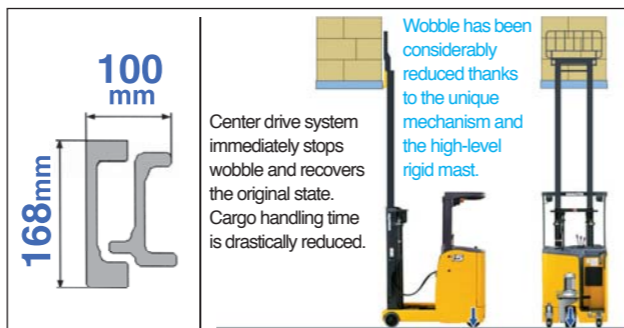

Suspension type

Wobble of the chassis can result from the rear wheel suspension sinking, insufficient rigidity of the mast or other reasons, leading to an increased cycle time.

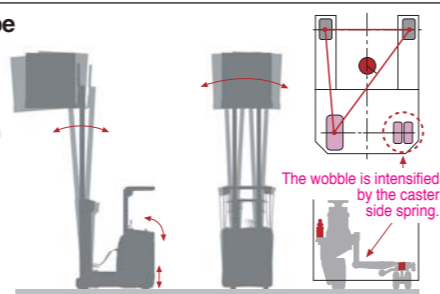

The viscous damper ensures high turn stability

Combined with Komatsu's original Center Drive System, the revolutionary viscous damper, that is employed in Komatsu construction machinery and highly reputed, reduces wobbling of the machine during turning considerably. As the result, the cycle time is reduced.

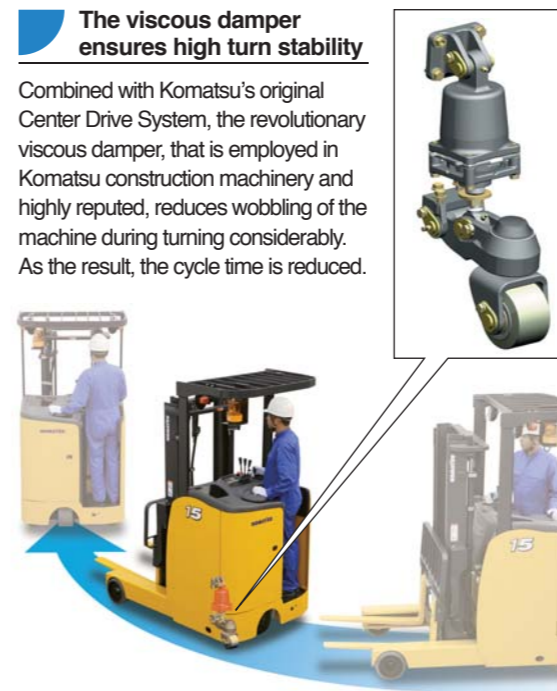

High gripping performance ensures positive traction

In the Center Drive System, by moving the drive tyre closer to the center of the chassis, the stopping mechanism reduces off-center drift when braking. When starting and braking, drive torque force is transmitted effectively from the tyres to the floor surface ensuring positive traction. This positive drive force results in faster work performance in all floor conditions.

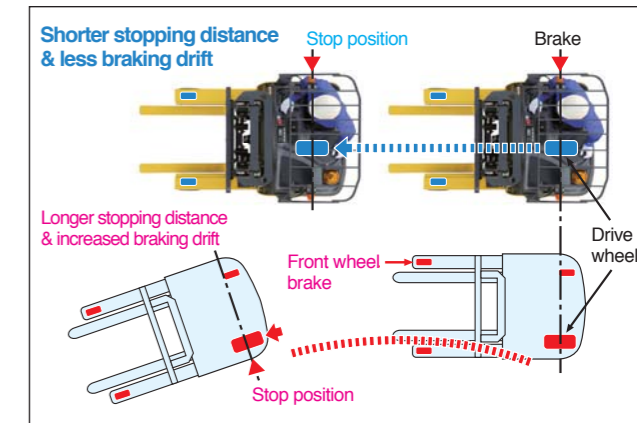

The accelerator neutral regeneration function allows quick and fine control of the machine

* Ask Komatsu service personnel for adjustment of the accelerator neutral regeneration function.

Since the machine is equipped with the accelerator neutral regeneration function, the operator can perform smooth plugging of the machine. When the accelerator lever is moved to the neutral position, the machine starts to decelerate gradually. This fine control function contributes to prevention of load dropping. In addition, this function reduces the need to use the foot brake, resulting in less operator's fatigue. Thus, comfortable and safe controllability of the machine minimizes stress on the operator drastically.

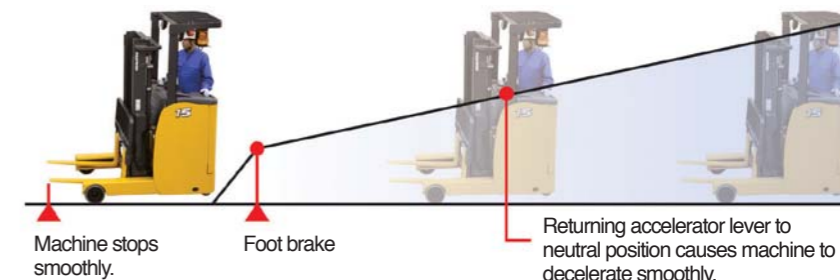

Komatsu technologies reduce operating costs

AC motor features high efficiency and low operating cost

AC motors continue to be used as the drive motor and pump motor. Since AC motors feature longer operating time per charge, the time to be used for charging is reduced and longer working hours can be spent on actual work. In addition, AC motors eliminate the need to replace motor brushes and contacts, which is inevitably required for DC motors. Thus, the downtime is reduced and the maintenance cost is also reduced.



Large drive tyre ensures excellent stability

The Center Drive System that has high gripping performance and securely receives the load prevents the drive tyre from running idle when the machine starts to move or is set for plugging. Combined with implementation of 360 mm large-diameter tyre, the tyre life is further extended resulting in reduced tyre replacement cost.

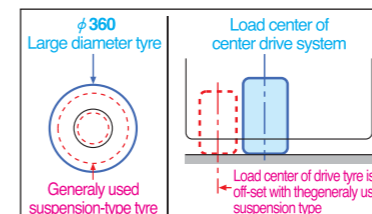

PC-based setup in which finer adjustment and setup are available

In addition to the setup function using the meter panel, the machine is equipped with the PC-based setup function* as standard equipment. This function allows independent adjustment of intensity, speed, and other properties of plugging, stopping, starting, brake, accelerator, etc. according to your work and maneuvering feeling of the operator. You can perform quick and precise troubleshooting in case of a failure thanks to this function. Thus, the machine has excellent maintainability.

* Ask Komatsu service personnel to perform the PC-based setup.



Battery front removal structure reduces workloads and maintenance costs

A battery removal mechanism is employed to facilitate the daily supply of electrolyte to or replacement of the battery. Reduced labor for this periodical work contributes to reduction in time and cost for this task.



Komatsu new reach trucks satisfy both safety and operator's comfort at high levels



Advanced Komatsu technologies for satisfaction both safety and operator's comfort

The Operator Presence Sensing system stops travel and lifting when operator is absent

The interlock mechanism conforming to ISO 3691-1 safety standards is equipped as standard. If the operator leaves the forklift, the travel motion slows to forward momentum and then stops and lifting also stops. This protects the operator from malfunctions and unforeseen accidents.

Traveling interlocking mechanism cuts power transmission off but not serve to apply the brake.



The lifting work interlock is displayed on the monitoring system



The floor switch structure allows easy getting on and off



Travel and lifting are stopped when the operators leaves the compartment

Reliable emergency switch to prepare for emergencies

The machine is equipped with the emergency power supply shutoff button to protect the operator and precious cargos in case of emergencies. In an emergency, the electric emergency switch allows the operator to turn off power of the truck with light effort.



Automatic power off function prevents wasting of battery power

Automatic power off function is installed as standard equipment. If a machine is not operated for 15 minutes, the drive system power automatically goes off. It prevents wasting of battery power.

Designs to reduce burden of operator

● Reduced floor height design

The reduced floor height design has substantially reduced the burden from frequent entering and exiting the machine during work. And the floor mat absorbs vibrations to alleviate operator fatigue.



● Thicker waist support pad

The thick support pad securely backs up the operator. It reduces stress on the waist and general fatigue considerably.



Various devices to support high level of work efficiency and safety

Easy- and light-to-operate controls

● Small diameter steering wheel

The steering wheel is located at the optimal place for ease of operation. The compact small diameter steering wheel allows control of the machine with less turn.



● Assist grip

The assist grip integrated with arm pad is installed as standard equipment. You can operate the accelerator lever while holding the grip.



● Brake pedal

Pedal effort of the foot brake that is frequently used is lowered to reduce fatigue of the operator.



● Backlit meter panel

The size, layout, and shape of the meter panel are optimized. The backlit meter panel is easy-to-read and allows the operator to know machine conditions at a glance even in dark places.



● Load backrest

The lower plate of load backrest is inclined to provide good front visibility. This design facilitates position checking during loading and unloading operations.



● Fork soft-landing device

This device automatically decreases lowering speed of the fork immediately before the fork touches the floor. As a result, landing shock of the fork is minimized and the floor is not damaged. Furthermore, landing noise is minimized to provide comfortable work environment.



Devices to improve safety (optional)

● LED head light

LED head lights feature longer service life and high brightness and provide good visibility.



● LED yellow strobe light

LED yellow strobe light features longer service life and is highly visible. This lamp securely calls attention of persons around to the machine.



Performance property setup function

Travel speed and lifting force of the machine are easily set by using buttons according to the work and maneuvering feeling of the operator. In addition, this function allows adjustment of reach speed, lift speed and setting of braking force as well. Finer setting of the machine properties realizes smoother operation.



Each machine property has a wide setting range to meet your requirement.

Brake regeneration	1-100
Soft-start	6 stages
Attachment speed	0-100
Accelerating speed	4 stages
Travel speed limit	

* Ask Komatsu service personnel to perform setting of the machine according to maneuvering feeling of the operator.

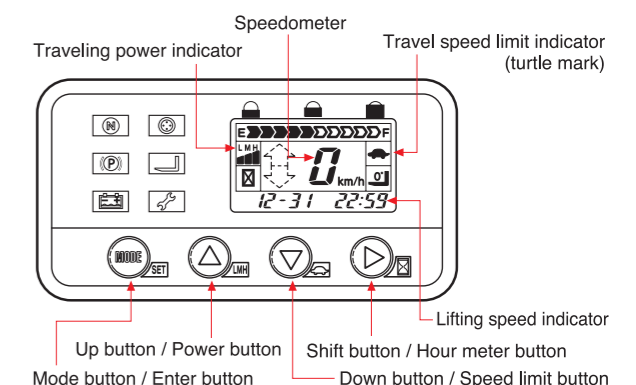

Major equipment / Line up

●:Stadard ○:Option △:Available upon request -:N/A S:Adjustable by service mechanic

Equipment and Function	Model	RL Type				RW Type		
		FB10RL(F)-15	FB13RL(F)-15	FB15RL(F)-15	FB18RL(F)-15	FB10RW-15	FB13RW-15	FB15RW-15
ICS (Intelligent Computer Control System)		●	●	●	●	●	●	
Motors	Drive Motor	AC	AC	AC	AC	AC	AC	
	Pump Motor	AC	AC	AC	AC	AC	AC	
	Electric Power Steering (EPS)	●	●	●	●	●	●	
Viscous Damper		●	●	●	●	●	●	
CAN-Bus Network		●	●	●	●	●	●	
Setup	Traveling Property Adjustment	Traveling Speed Property	●	●	●	●	●	●
		Plugging Regeneration Property	●(S)	●(S)	●(S)	●(S)	●(S)	●(S)
		Brake Regeneration Property	●(S)	●(S)	●(S)	●(S)	●(S)	●(S)
		Soft-start Property	●(S)	●(S)	●(S)	●(S)	●(S)	●(S)
		Accelerator Property	●(S)	●(S)	●(S)	●(S)	●(S)	●(S)
		Accelerator Neutral Regeneration Property	●(S)	●(S)	●(S)	●(S)	●(S)	●(S)
		Slope Regeneration	●(S)	●(S)	●(S)	●(S)	●(S)	●(S)
	Hydraulic Operation Property Adjustment	Traveling Speed Control	●	●	●	●	●	●
		Lifting Speed Adjustment	●	●	●	●	●	●
		Tilting Speed Adjustment	●(S)	●(S)	●(S)	●(S)	●(S)	●(S)
IMS (Intelligent Monitoring System)	Attachement Speed	●(S)	●(S)	●(S)	●(S)	●(S)	●(S)	
	Speedometer	●	●	●	●	●	●	
	Forward/Reverse Indicator	●	●	●	●	●	●	
	Speed Limit Indicator	●	●	●	●	●	●	
	Calendar/Service Meter	●	●	●	●	●	●	
	Traveling Power Indicator	●	●	●	●	●	●	
	Battery Discharge Indicator	●	●	●	●	●	●	
	Neutral Start Indicator	●	●	●	●	●	●	
	Traveling Operator Presence Sensing Warning Lamp	●	●	●	●	●	●	
	Lifting Operator Presence Sensing Warning Lamp	●	●	●	●	●	●	
Operation Equipment Related	Failure Indicator	●	●	●	●	●	●	
	Anti-slip Control	●	●	●	●	●	●	
	Operating Lever With Rubber Boots	●	●	●	●	●	●	
	Soft-landing Device	●	●	●	●	●	●	
	Operator Presence Sensing System (Lifting/Traveling Interlocking Mechanism)	●	●	●	●	●	●	
	Emergency Switch	●	●	●	●	●	●	
	Neutral Start System (Traveling / Lifting)	●	●	●	●	●	●	
	Automatic Power Off	●	●	●	●	●	●	
	Anti Roll-back	●	●	●	●	●	●	
	Travel Speed Limit	●	●	●	●	●	●	
Safety Equipment	Key-off Lift Lock	●	●	●	●	●	●	
	Back-up Buzzer	●	●	●	●	●	●	
	Load Checker	○	○	○	○	○	○	
	Forward/Back-up Chime	○	○	○	○	○	○	
	Wide-angle Center Mirror	○	○	○	○	○	○	
	Assist Grip	●	●	●	●	●	●	
	Head Light	●	●	●	●	●	●	
	LED Head Light *1	○	○	○	○	○	○	
	Turn Signal Lamps	○	○	○	○	○	○	
	Rear Working Light	○	○	○	○	○	○	
Supportive Equipment for Hydraulic Operation	LED Yellow Strobe Light *1	○	○	○	○	○	○	
	Strobe Light (Linked With Key Switch)	Yellow	○	○	○	○	○	
		Red	○	○	○	○	○	
		Blue	○	○	○	○	○	
	Lamp For Operator's Hand	○	○	○	○	○	○	
	Fire Extinguisher	○	○	○	○	○	○	
	Leser Lift Height Sensor	○	○	○	○	○	○	
	Automatic Lifting Stop Function (with Fork Leveling Device)	-	-	○	○	-	-	
	Softcarry (Hydraulic Accumulator) *2	○	○	○	○	○	○	
	Hydraulic Oil Gauge	●	●	●	●	●	●	
Check Device	Self-diagnostic System	●	●	●	●	●	●	
		●	●	●	●	●	●	
Exterior	Floor Mat	●	●	●	●	●	●	
	Soft Vinyl Head Guard Cover	○	○	○	○	○	○	
Battery Charger-related	Paper Binder	●	●	●	●	●	●	
	Stationary Battery Charger	○	○	○	○	○	○	
	Battery Front Removal Structure	●	●	●	●	●	●	
	Battery 201AH/5H	○	○	○	○	○	○	
	Battery 225AH/5h	○	○	○	○	○	○	
	Battery 240AH/5h	○	○	○	○	○	○	
	Battery 280AH/5h	-	-	-	-	-	-	
	Battery 312AH/5h	-	-	-	-	-	-	
Battery 370AH/5h	-	-	-	-	-	-		
Battery 390AH/5h	-	-	-	-	-	-		

*1: For normal temperature models only *2: Available for 2-stage free view mast only

RL type

FB10RL/FB13RL/FB15RL/FB18RL

The RL type employs Komatsu's original Center Drive System and ensures excellent gripping force, even on slippery surfaces. The design keeps residual capacity high and realizes stable drive performance and powerful work.

Cold-storage Models

FB10RLF/FB13RLF/FB15RLF/FB18RLF

Cold-storage models are designed to operate at temperatures down to -35°C. These models are also suited for operation at room temperature.

Major features for Cold-storage Models

- Controller cover
- Special hydraulic oil and grease
- Anticorrosive coating: Transfer, Load wheel, Drive wheel, Caster wheel, Steering system, Frame, Overhead guard, Service door, Cylinders, Mast, Hydraulic oil tank, Load backrest & fork carriage, Forks.



RW type

FB10RW/FB13RW/FB15RW

The RW type employs a suspension system, which greatly reduces vibration and shocks when traveling on uneven floors or over gaps.

It gives greater stability during unloaded turns and ensures excellent maneuverability on any worksite.



Specifications

Characteristics	Model	Manufacture's Designation	FB10RL(F)-15	FB13RL(F)-15	FB15RL(F)-15	FB18RL(F)-15	FB10RW-15	FB13RW-15	FB15RW-15	
			1.2	Power Type	Electric, Diesel, Gasoline, LPG, Cable	Electric	Electric	Electric	Electric	Electric
1.4	Operation Type	Pedestrian, Driver Standing, Sitting, Order Picking	Standing	Standing	Standing	Standing	Standing	Standing	Standing	
1.5	Rated Capacity	Q1 Rated Capacity	kg	1000	1250	1500	1800	1000	1250	
1.6	Load Center	c Load Center	mm	500	500	500	500	500	500	
1.6.1	Alternative Capacity	Q2 Capacity @ 600mm Load Center	kg	870	1080	1300	1560	870	1080	
1.8	Load Distance	x Front Axle Center to Fork Face	mm	175	175	175	175	175	175	
1.9	Wheelbase	y	mm	1110	1250	1350	1500	1110	1250	
2.1	Service Weight	Including Min. Capacity Battery, see line 6.5	kg	1985	2000	2175	2255	1985	2000	
Weight	2.4 Axle Loading Mast/Forks Extended	Loaded	kg	2545	2845	3235	3610	2545	2845	
		Front	kg	440	405	440	445	440	405	
		Rear	kg	895	880	940	960	900	880	
	2.5 Axle Loading Mast/Forks Retracted	Unloaded	kg	1090	1120	1235	1295	1085	1120	
		Front	kg	1935	2010	2345	2455	1935	2010	
		Rear	kg	1050	1240	1330	1600	1050	1235	
Tyre	3.1 Tyre Type	3.2	Front	φ 260x120	φ 260x120	φ 254x114	φ 254x120	φ 260x120	φ 260x120	
		3.3	Rear	φ 360x180	φ 360x180	φ 360x180	φ 360x180	φ 330x145	φ 330x145	
		3.4	Additional Wheels	φ 127x90	φ 127x90	φ 127x90	φ 127x90	φ 150x80	φ 150x80	
	3.5 Number of Wheel	Front/Rear (=driven)	2/1*+2	2/1*+2	2/1*+2	2/1*+2	2/1*+2	2/1*+2	2/1*+2	
		3.6	Tread, Front	b10	mm	975	975	975	975	975
		3.7	Tread, Rear	b11	mm	-	-	-	-	-
Dimensions	4.1	Tilting Angle	α/β	Forward/Backward	degree	3/5	3/5	3/5	3/5	
	4.2	Mast Height, Lowered	h1	with Std. Mast	mm	1995	1995	1995	1995	
	4.3	Std. Free Lift	h2	with Std. Mast, from Ground	mm	105	105	105	105	
	4.4	Std. Lift Height	h3	with Std. Mast, from Ground	mm	3000	3000	3000	3000	
	4.5	Mast Height, Extended	h4	with Std. Mast	mm	3935	3935	3935	3935	
	4.7	Height, Overhead Guard	h6		mm	2245	2245	2245	2245	
	4.19	Length, with Std. Forks	l1		mm	1905	1905	2005	2075	
	4.21	Width, at Tyre	b1		mm	1095	1095	1095	1080	
	4.22	Forks	s/e/l	Thickness/Width/Length	mm	35x100x850	35x100x850	35x100x850	38x100x920	
	4.23	Fork Carriage Class				Pin Mount	Pin Mount	Pin Mount	Pin Mount	
Performance	4.24	Width, Fork Carriage	b3		mm	750	750	750	750	
	4.26	Width, between Reach Legs	b4		mm	752	752	752	752	
	4.28	Reach Travel	l4		mm	440	580	580	730	
	4.31	Ground Clearance	m1	under the Mast	mm	75	75	75	75	
	4.32		m2	at the center of Wheelbase	mm	80	80	80	80	
	4.33	Right Angle Stacking Aisle	As1	with L1000 x W1200 pallet	mm	2275	2310	2405	2460	
	4.34		As2	with L1200 x W800 pallet	mm	2340	2355	2450	2475	
	4.35.1	Turning Radius	Wa		mm	1325	1465	1560	1715	
	4.35.2		Wb		mm	670	555	555	555	
	4.37	Length, without Forks	l7		mm	1470	1610	1710	1860	
Drive	5.1	Travel Speed (FWD)	Loaded/Unloaded	km/h	9.5/10.5	9.5/10.5	9.5/10.5	9.5/10.5	9.5/10.5	
	5.2	Lifting Speed	Loaded/Unloaded	mm/s	350/540	320/540	320/540	300/540	350/540	
	5.3	Lowering Speed	Loaded/Unloaded	mm/s	500/550	460/550	460/550	460/550	500/550	
	5.4	Reach Speed	Loaded/Unloaded	mm/s	300/300	300/300	300/300	300/300	300/300	
	5.6	Max. Drawbar Pull	3min rating	N	5880	5880	5880	5880	6080	
	5.8	Max. Gradeability	Unloaded 1.5Km/h, 3min rating	%	32	31	28	27	32	
	5.10	Service Brake	Operation/Control		Mechanical, Disc	Mechanical, Disc	Mechanical, Disc	Mechanical, Disc	Mechanical, Disc	
	5.11	Parking Brake	Operation/Control		Mechanical, Disc	Mechanical, Disc	Mechanical, Disc	Mechanical, Disc	Mechanical, Disc	
	5.12	Steering	Operation/Control		Electric Power Steering	Electric Power Steering	Electric Power Steering	Electric Power Steering	Electric Power Steering	
	Others	6.1	Drive Motor (AC)	60min rating	kW	4.5	4.5	4.5	4.5	4.5
6.2		Pump Motor (AC)	5min rating	kW	9.0	9.0	9.0	9.0	9.0	
6.2.1		PS Motor (DC)	60min rating	kW	0.3	0.3	0.3	0.3	0.3	
6.4		Battery Voltage		V	48	48	48	48	48	
6.4.1		Battery Capacity, Min.	Ah/5-hour	201	201	280	201	201	280	
6.4.2	Battery Capacity, Max.	Ah/5-hour	240	240	390	390	240	240		
6.5	Battery Weight, Min. Capacity	kg	365	365	495	495	365	365		
8.1	Drive Motor Control		MOS-FET inverter	MOS-FET inverter	MOS-FET inverter	MOS-FET inverter	MOS-FET inverter	MOS-FET inverter		
8.1.1	Pump Motor Control		MOS-FET inverter	MOS-FET inverter	MOS-FET inverter	MOS-FET inverter	MOS-FET inverter	MOS-FET inverter		
8.1.2	PS Motor Control		MOS-FET chopper	MOS-FET chopper	MOS-FET chopper	MOS-FET chopper	MOS-FET chopper	MOS-FET chopper		
8.2	Relief Pressure for Attachment	bar	167	167	167	167	167	167		
8.2.1	Hydraulic Tank Capacity	Ltr	16	16	16	16	16	16		

Dimensions

