

ZAXIS-5G series
Super Long Front

HITACHI

Reliable solutions

SUPER LONG FRONT

ZAXIS200_{LC}

A P P L I C A T I O N & A T T A C H M E N T



Model Code	ZX200LC-5G
Engine Rated Power	125 kW (168 HP)
Operating Weight	21 500 - 22 200 kg

SPECIFICATIONS

ZX200LC-5G TYPE H15 SUPER LONG FRONT

ENGINE

Model	Isuzu CC-6BG1T
Type	4-cycle water-cooled, direct injection
Aspiration	Turbocharged, intercooled
No. of cylinders	6
Rated power	
ISO 9249, net	125 kW (168 HP) at 2 100 min ⁻¹ (rpm)
SAE J1349, net	125 kW (168 HP) at 2 100 min ⁻¹ (rpm)
Maximum torque	637 Nm (65 kgfm) at 1 800 min ⁻¹ (rpm)
Piston displacement ..	6.494 L
Bore and stroke	105 mm x 125 mm
Batteries	2 x 12 V / 88 Ah

HYDRAULIC SYSTEM

Hydraulic Pumps

Main pumps	2 variable displacement axial piston pumps
Maximum oil flow ..	2 x 212 L/min
Pilot pump	1 gear pump
Maximum oil flow ..	33.6 L/min

Hydraulic Motors

Travel	2 variable displacement axial piston motors
Swing	1 axial piston motor

Relief Valve Settings

Implement circuit	34.3 MPa (350 kgf/cm ²)
Swing circuit	26.8 MPa (273 kgf/cm ²)
Travel circuit	34.3 MPa (350 kgf/cm ²)
Pilot circuit	3.9 MPa (40 kgf/cm ²)
Power boost	38.0 MPa (388 kgf/cm ²)

Hydraulic Cylinders

	Quantity	Bore	Rod diameter
Boom	2	120 mm	85 mm
Arm	1	135 mm	100 mm
Bucket	1	95 mm	65 mm

UPPERSTRUCTURE

Revolving Frame

D-section frame skirt for resistance to deformation.

Swing Device

Axial piston motor with planetary reduction gear is bathed in oil. Swing circle is single-row. Swing parking brake is spring-set/hydraulic-released disc type.

Swing speed	13.5 min ⁻¹ (rpm)
Swing torque	53 kNm (5 390 kgfm)

Operator's Cab

Independent spacious cab, 1 005 mm wide by 1 675 mm high, conforming to ISO* Standards.

* International Organization for Standardization

UNDERCARRIAGE

Tracks

Heat-treated connecting pins with dirt seals. Hydraulic (grease) track adjusters with shock-absorbing recoil springs.

Numbers of Rollers and Shoes on Each Side

Upper rollers	2
Lower rollers	8
Track shoes	49
Track guard	1

Travel Device

Each track driven by 2-speed axial piston motor. Parking brake is spring-set/hydraulic-released disc type. Automatic transmission system: High-Low.

Travel speeds	High : 0 to 5.5 km/h
	Low : 0 to 3.5 km/h

Maximum traction force .. 203 kN (20 700 kgf)

Gradeability

SERVICE REFILL CAPACITIES

Fuel tank	400.0 L
Engine coolant	23.0 L
Engine oil	25.0 L
Swing device	6.2 L
Travel device (each side).....	6.8 L
Hydraulic system	240.0 L
Hydraulic oil tank	135.0 L

WEIGHTS AND GROUND PRESSURE

ZX200LC-5G TYPE H15 SUPER LONG FRONT:

Equipped with 8.14 m boom, 6.33 m arm and 0.45 m³ bucket (SAE, PCSA heaped), 5 400 kg counterweight.

Shoe type	Shoe width	Operating weight	Ground pressure
Triple grouser	600 mm	21 500 kg	47 kPa (0.48 kgf/cm ²)
	700 mm	21 900 kg	41 kPa (0.42 kgf/cm ²)
	800 mm	22 200 kg	36 kPa (0.37 kgf/cm ²)

Basic Machine Weight and Overall width

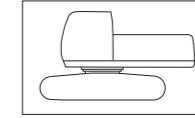

Excluding front end attachment, additional counterweight, fuel, hydraulic oil and coolant etc. Including counterweight.

ZX200LC-5G

Shoe width	Weight	Overall width
600 mm	17 100 kg	2 990 mm
700 mm	17 500 kg	3 090 mm
800 mm	17 800 kg	3 190 mm

BUCKET SPECIFICATIONS AND COMPATIBILITY

ZX200LC-5G

	Capacity ISO heaped	Width Without side cutters	Weight	Recommendation
				ZX200LC-5G
				H15
Backhoe	0.45 m ³	850 mm	320 kg	◎
Slope finishing	-	1 500 mm	360 kg	◇
Max.weight				1 130 kg

◎ Suitable for materials with density of 1 800 kg/m³ or less

◇ Slope-finishing service



SPECIFICATIONS

ZX200LC-5G TYPE H15 SUPER LONG FRONT

WORKING RANGES

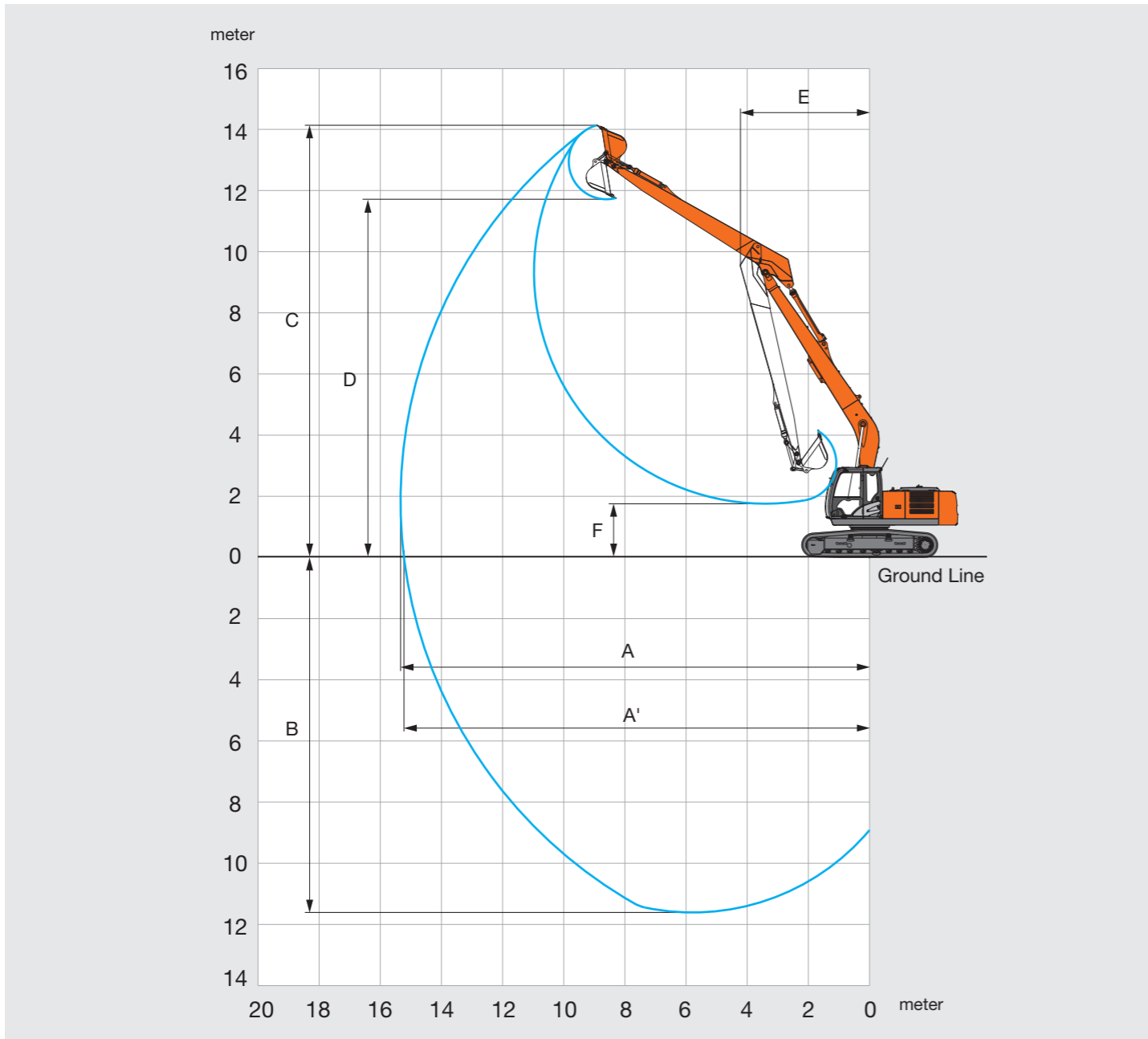

Unit: mm

ZX200LC-5G TYPE H15	
A Max. digging reach	15 340
A' Max. digging reach (on ground)	15 230
B Max. digging depth	11 630
C Max. cutting height	14 110
D Max. dumping height	11 690
E Min. swing radius	4 230
F Min. dumping height	1 730
Bucket digging force ISO	84 kN (8 500 kgf)
Bucket digging force SAE:PCSA	73 kN (7 400 kgf)
Arm crowd force ISO	47 kN (4 800 kgf)
Arm crowd force SAE:PCSA	46 kN (4 700 kgf)

•Excluding track shoe lug

DIMENSIONS

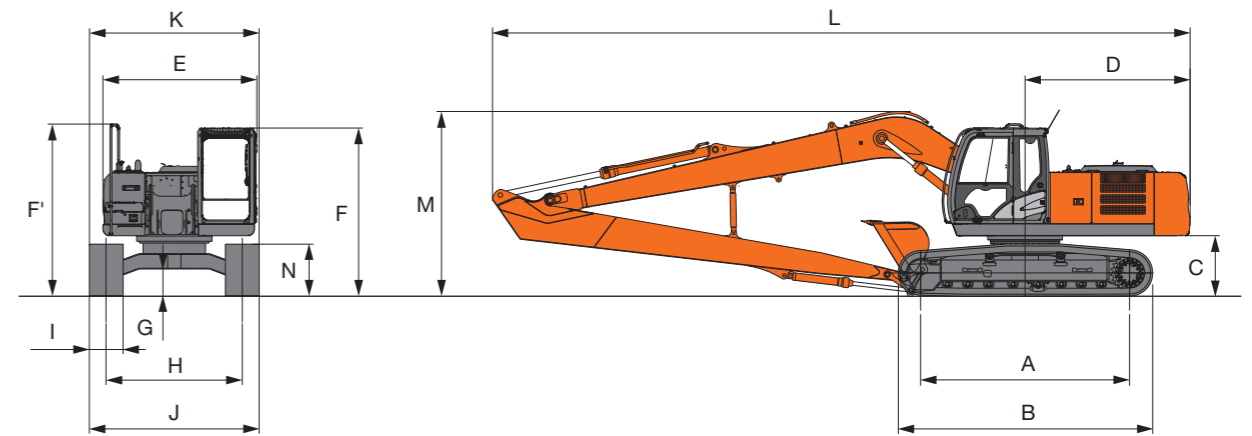

Unit: mm

ZX200LC-5G TYPE H15	
A Distance between tumbler	3 660
B Undercarriage length	4 460
* C Counterweight clearance	1 030
D Rear-end swing radius	2 890
E Overall width of upperstructure	2 710
F Overall height of cab	2 950
F' Overall height of upperstructure	3 010
* G Min. ground clearance	450
H Track gauge	2 390
I Track shoe width	G 600 / G 700 / G 800
J Undercarriage width	2 990 / 3 090 / 3 190
K Overall width	2 990 / 3 090 / 3 190
L Overall length	12 210
M Overall height	3 230
N Track height with triple grouser shoes	920

* Excluding track shoe lug

LIFTING CAPACITIES (Without Bucket)

Notes: 1. Ratings are based on ISO 10567.

2. Lifting capacity does not exceed 75% of tipping load with the machine on firm, level ground or 87% full hydraulic capacity.

3. The load point is the center-line of the bucket pivot mounting pin on the arm.

4. *Indicates load limited by hydraulic capacity.

5. 0 m = Ground.

For lifting capacities, subtract bucket and quick hitch weight from lifting capacities without bucket.

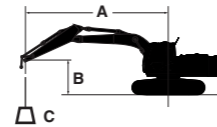

A: Load radius

B: Load point height

C: Lifting capacity

ZX200LC-5G TYPE H15 SUPER LONG FRONT

Rating over-front Rating over-side or 360 degrees Unit : kg

Conditions	Load point height m	Load radius											
		1.5 m		3.0 m		4.5 m		6.0 m		7.5 m		9.0 m	
		Rating over-front	Rating over-side or 360 degrees	Rating over-front	Rating over-side or 360 degrees	Rating over-front	Rating over-side or 360 degrees	Rating over-front	Rating over-side or 360 degrees	Rating over-front	Rating over-side or 360 degrees	Rating over-front	Rating over-side or 360 degrees
Boom 8.14 m	10.5												
Arm 6.33 m	9.0												
Counterweight 5 400 kg	7.5												
Shoe 600 mm	6.0											*2 600	*2 600
	4.5											*2 920	*2 920
	3.0					*5 630	*5 630	*4 390	*4 390	*3 720	*3 720	*3 310	3 000
	1.5			*2 630	*2 630	*7 580	7 410	*5 440	4 990	*4 350	3 660	*3 710	2 810
	0 (Ground)			*2 250	*2 250	*5 950	*5 950	*6 310	4 560	*4 920	3 390	*4 090	2 630
	-1.5	*1 840	*1 840	*2 790	*2 790	*5 310	*5 310	*6 900	4 270	5 120	3 190	3 970	2 500
	-3.0	*2 690	*2 690	*3 590	*3 590	*5 760	*5 760	6 860	4 120	4 980	3 060	3 870	2 400
	-4.5	*3 600	*3 600	*4 570	*4 570	*6 720	6 130	6 800	4 060	4 910	3 010	3 820	2 360
	-6.0	*4 600	*4 600	*5 740	*5 740	*8 140	6 210	6 830	4 090	4 920	3 010	3 820	2 360
	-7.5	*5 760	*5 760	*7 200	*7 200	*8 450	6 390	*6 470	4 190	5 000	3 080	3 890	2 430
	-9.0			*9 170	*9 170	*7 100	6 660	*5 490	4 380	*4 320	3 230		

Conditions	Load point height m	Load radius						At max. reach		
		10.5 m		12.0 m		13.5 m		meter		
		Rating over-front	Rating over-side or 360 degrees	Rating over-front	Rating over-side or 360 degrees	Rating over-front	Rating over-side or 360 degrees	Rating over-front	Rating over-side or 360 degrees	meter
Boom 8.14 m	10.5	*1 610	*1 610					*1 080	*1 080	11.1
Arm 6.33 m	9.0	*2 070	*2 070	*1 170	*1 170			*1 020	*1 020	12.1
Counterweight 5 400 kg	7.5	*2 310	*2 310	*1 810	*1 810			*980	*980	12.9
Shoe 600 mm	6.0	*2 550	*2 550	*2 160	2 000	*970	*970	*970	*970	13.5
	4.5	*2 780	2 460	*2 460	1 940	*1 450	*1 450	*980	*980	13.8
	3.0	*3 030	2 340	*2 780	1 860	*1 740	1 490	*1 000	*1 000	14.1
	1.5	*3 300	2 220	2 780	1 780	*1 900	1 450	*1 040	*1 040	14.1
	0 (Ground)	3 290	2 100	2 700	1 710	*1 890	1 400	*1 100	*1 100	14.0
	-1.5	3 190	2 010	2 640	1 650	*1 590	1 380	*1 190	*1 190	13.7
	-3.0	3 130	1 940	2 600	1 610			*1 320	*1 320	13.2
	-4.5	3 100	1 920	2 600	1 610			*1 510	*1 510	12.6
	-6.0	3 110	1 930					*1 790	1 700	11.7
	-7.5	*2 290	2 020					*2 290	2 020	10.5
	-9.0							*3 280	2 610	8.94

EQUIPMENT

ZX200LC-5G TYPE H15 SUPER LONG FRONT

Standard and optional equipment may vary by country, so please consult your Hitachi dealer for details.

● : Standard equipment

○ : Optional equipment

ENGINE	
Air cleaner double filters	●
Auto idle system	●
Cartridge-type engine oil filter	●
Cartridge-type fuel pre-filter	●
Cartridge-type fuel main filter	●
Dry-type air filter with evacuator valve (with air filter restriction indicator)	●
ECO/PWR mode control	●
Engine warm-up device	●
Fan guard	●
Water separator	●
Pre-cleaner	○
Dust-Proof indoor net	●
Radiator reserve tank	●
50 A alternator	●

HYDRAULIC SYSTEM	
Auto power lift	●
Control valve with main relief valve	●
Full-flow filter	●
High mesh full flow filter with restriction indicator	○
Pilot filter	●
Power boost	●
Suction filter	●
One extra port for control valve	●
Work mode selector	●

CAB	
All-weather sound suppressed steel cab	●
AM-FM radio with 2 speakers	●
Ashtray	●
Auto control air conditioner	●
AUX. terminal and storage	○
Cab (Center pillar reinforced structure)	●
Drink holder (rear side)	●
Drink holder with hot & cool (front side)	●
Electric double horn	●
Engine shut-off lever	●
Evacuation hammer	●
Fire extinguisher bracket	○
Floor mat	●
Footrest	●
Front window washer	●
Front windows on upper, lower and left side can be opened	●
Lower cab front guard	○
Upper cab front guard	○
Glove compartment	●
Hot & cool box	●
Intermittent windshield wipers	●
Key cylinder light	●
LED room light with door courtesy	●
OPG top guard Level I (ISO10262) compliant cab	●
Pilot control shut-off lever	●
Rear tray	●
Retractable seat belt	●
Rubber radio antenna	●
Seat : Fabric seat	●
Seat : mechanical suspension seat	○
Seat : air suspension seat with heater	○
Seat adjustment part : backrest, armrest, height and angle, slide forward / back	●
Short wrist control levers	●
4 fluid-filled elastic mounts	●
24V cigarette lighter	●

MONITOR SYSTEM	
Alarm buzzers: overheat, engine oil pressure, overload	●
Alarms: overheat, engine warning, engine oil pressure, alternator, minimum fuel level, hydraulic filter restriction, air filter restriction, work mode, overload, etc	●
Display of meters: water temperature, hour, fuel rate, clock	●
Other displays: work mode, auto-idle, glow, operating conditions, etc	●
32 languages selection	●

LIGHTS	
Additional cab roof front lights	○
Additional boom light with cover	○
2 working lights	●

UPPER STRUCTURE	
Electric fuel refilling pump	○
Fuel level float	●
Hydraulic oil level gauge	●
Rear view camera	○
Rear view mirror (right & left side)	●
Swing parking brake	●
Tool box	●
Undercover	●
Utility space	●
5 400 kg counterweight	●
2 x 88 Ah batteries	●

UNDERCARRIAGE	
Bolt-on sprocket	●
Reinforced track links with pin seals	●
Travel motor covers	●
Travel parking brake	●
9.0 mm reinforced track undercover	○
Track guard (each side) and hydraulic track adjuster	●
Upper and lower rollers	●
2 track guards	○
4 tie down hooks	●
600 mm triple grouser shoes	●
700 / 800 mm triple grouser shoes	○

FRONT ATTACHMENTS	
Centralized lubrication system	●
Flanged pin	●
HN bushing	●
0.45 m ³ bucket (ISO heaped)	●
6.33 m arm	●
8.14 m boom	●

ATTACHMENTS	
Additional pump (30 L/min)	○
Assist piping	○

MISCELLANEOUS	
Lockable fuel refilling cap	●
Lockable machine covers	●
Onboard information controller	●
Skid-resistant tapes, plates and handrails	●
Standard tool kit	●
Travel direction mark on track frame	●
Global e-Service	●



Built on the foundation of superb technological capabilities, Hitachi Construction Machinery is committed to providing leading-edge solutions and services to contribute as a reliable partner to the business of customers worldwide.

Hitachi Environmental Vision 2025

The Hitachi Group released the Environmental Vision 2025 to curb annual carbon dioxide emissions. The Group is committed to global production while reducing environmental impact in life cycles of all products, and realizing a sustainable society by tackling three goals — prevention of global warming, conservation of resources, and preservation of ecosystem.

Reducing Environmental Impact by New ZAXIS

Hitachi makes a green way to cut carbon emissions for global warming prevention according to LCA*. New ZAXIS utilizes lots of technological advances, including the new ECO mode, and Isochronous Control. Hitachi has long been committed to recycling of components, such as aluminum parts in radiators and oil cooler. Resin parts are marked for recycling.

*Life Cycle Assessment – ISO 14040

Before using a machine with a satellite communication system, please make sure that the satellite communication system complies with local regulations, safety standards and legal requirements. If not so, please make modifications accordingly.

These specifications are subject to change without notice.

Illustrations and photos show the standard models, and may or may not include optional equipment, accessories, and all standard equipment with some differences in color and features. Before use, read and understand the Operator's Manual for proper operation.