

CNN-MEA-12AV

MINI EXCAVATOR



PRODUCT INFORMATION

Certification:



Bucket Capacity	0.025m ³
Chassis Width	930mm
Track Length	1250mm
Gradeability	20°
Chassis Ground Clearance	385mm
Track Width	180mm
Volume of fuel tank	3.5L
Overall Dimension	2200*930*2200mm
Transport Length	2200mm
Excavator Height	2200mm
Hydraulic flow	18L/Min
Hydraulic tank capacity	13L
Working pressure	16Mpa

Engine	KOOP 192F Diesel Engine (Euro 5)
Engine Power	7.5kw
EPA Engine Optional	Briggs&Stratton gasoline /13.5hp
Max.Digging Height	2550mm
Max.Dumping Height	1850mm
Max.Digging Depth	1650mm
Max.Digging Radius	2400mm
Turning Radius	1190mm
Bucket excavating force	11KN
Operating Weight	850kg
Configuration	Valve:Beifang Brand Pump:Xingzou Brand Double Gear Pump

PRODUCT DETAIL

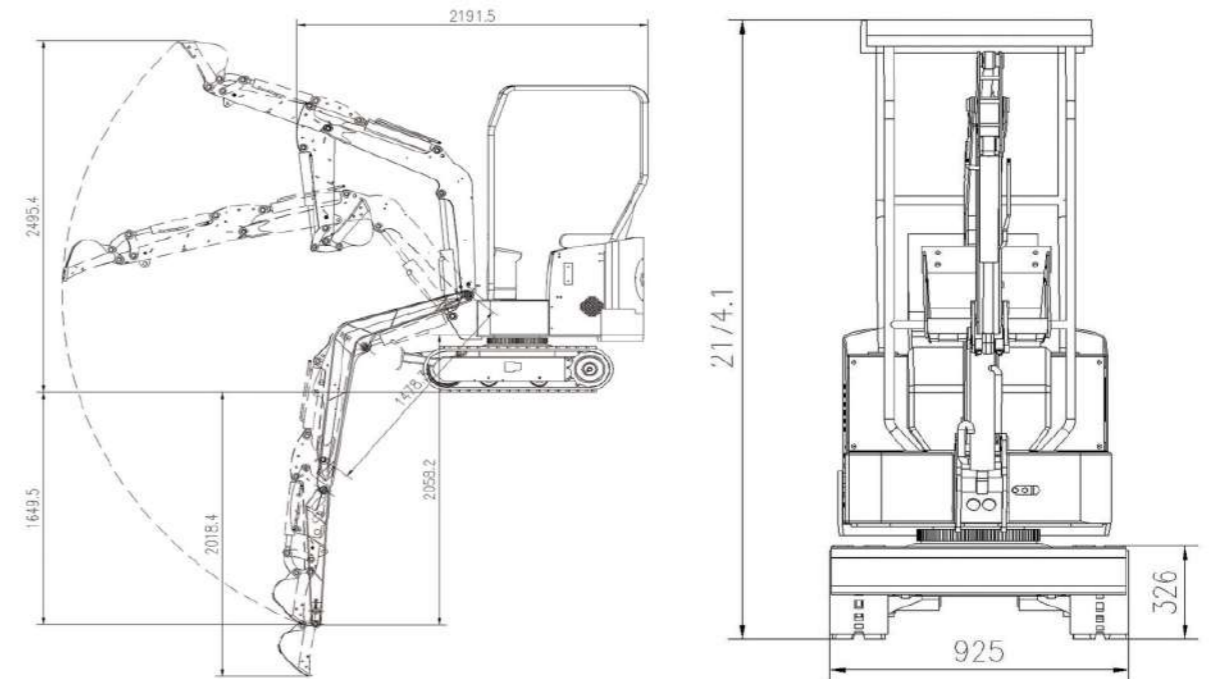

- Koop 192F diesel engine and B&S gasoline engine
- The bulldozer blade is widened and thickened, durable
- The pin comes with grease fitting, more lubricating
- Adjustable track optional
- Timer and voltmeter
- Swing boom optional