

Sumitomo SH120-3 Hydraulic Excavator Dimensions & Specs

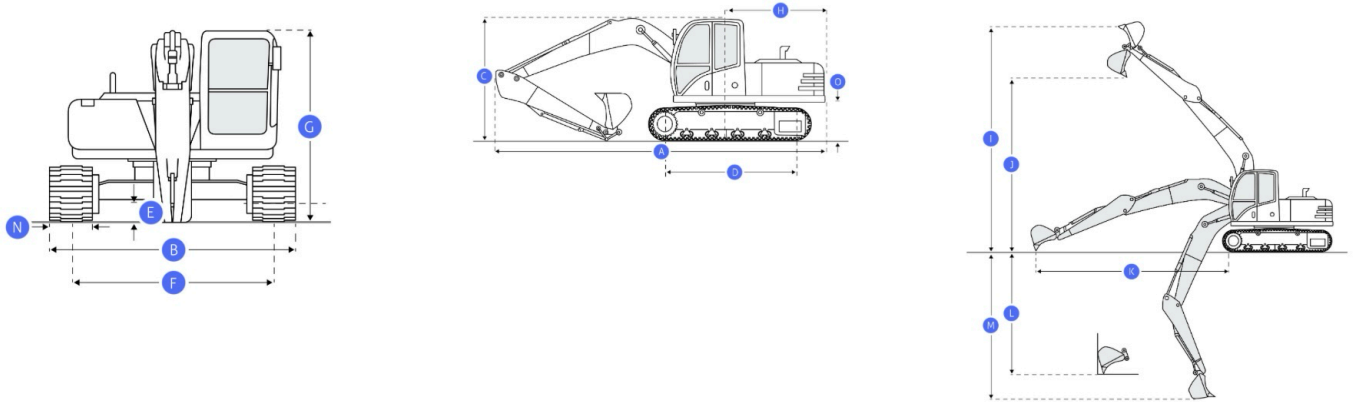

Boom/Stick Option (Hex) 1

A Shipping Length Of Unit	7490 mm
C Shipping Height Of Unit	2740 mm
I Max Cutting Height	9160 mm
J Max Loading Height	6760 mm
K Max Reach Along Ground	8270 mm
L Max Vertical Wall Digging Depth	4960 mm
M Max Digging Depth	5540 mm

Operational

Operating Weight	12000 kg
Fuel Capacity	250 L
Hydraulic System Fluid Capacity	123 L
Hydraulic System Relief Valve Pressure	34300 kPa