

**SANY**<sup>®</sup>

# SPECIFICATION



 **300t**

 **85m**

 **117m**

# SAC3000C8-8

SANY ALL TERRAIN CRANE

QUALITY CHANGES THE WORLD

[crane.sanyglobal.com](http://crane.sanyglobal.com)

V1.1

It is one of the core business units in SANY Group, specializing in the development and manufacturing of high-end wheel cranes, crawler cranes and tower cranes, including the complete range of wheel cranes from 8 to 2400t, crawler cranes from 25 to 4500t and tower cranes from 6 to 185t.

三一集团旗下核心事业部，从事高端轮式起重机、履带起重机、塔式起重机系列产品的研发制造。覆盖8-2400吨全吨位轮式起重机，25-4500吨全吨位履带起重机，6-185吨塔式起重机。



SANY CRANE



# SAC3000C8-8

SANY ALL TERRAIN CRANE  
300T LIFTING CAPACITY

8-section 85m oval shaped boom and fixed jib 22m are standard, and the jib can be added up to 36m optionally, easily handling the installation of 100m power transmission towers and air conditioners on high-rise buildings.

Y type superlift device is available, enhancing lifting performance at middle and long boom significantly.

The use of stable tensioning technology makes setup more efficient and operation safer.

Dual engines come from Weichai of high quality and compliance with emission standard.

HanDe axles supporting variable modes of transferring between jobsites: ① traveling at low speed with 67.5t CW onboard, ② traveling at maximum 40km/h with superlift, ③ traveling at maximum 40km/h with 10t bottom CW and four outrigger pads.

All new driver's cab and operator's cab, operator comfort and convenience greatly improved.

8节椭圆形主臂全伸85m，标配副臂22m，可选至36m。轻松完成百米线塔装配、高层建筑的空调等吊装。

Y型超起，中长臂段性能大幅增加。定长张紧技术应用，效率更高，作业更加安全。

上下车潍柴发动机，可靠性高。

汉德车桥，支持多种重载转场模式：①可带67.5吨主配重，低速转场；②带超起行驶，时速40km/h；③可自带10吨底配重+四块垫板行驶40km/h。

全新驾驶室、操纵室，舒适性及便捷性大幅提升。







## **i-Cab -Driver's cab**

### **新两室 - 驾驶室**

Multi-function seat with air suspension, making driving more comfortable.

Double seats and foldable berth for the co-driver.

12.1-inch automotive grade dash screen integrated with Reversing image and multi-media.

Electric rearview mirror with electric heating, ensuring good field of view in foul weather.

Adjustable high-brightness LED headlamps/fog lamps, providing clear vision at night.

Reversing sensor with accurate distance detection capability, fully covering the parking area without blind spots, and effectively avoiding scratch and collision.

Full-automatic HVAC, able to automatically adjust indoor temperature as demanded.

驾驶位配备气浮多功能座椅, 驾驶更舒适。

副驾驶位设置双座椅可折叠式卧铺。

12.1英寸车规级中控屏, 集成倒车影像、语音娱乐功能。

电动、电加热后视镜, 不惧恶劣冰雪天气。

高亮度可调节 LED 大灯 / 雾灯, 夜间视野清晰。

倒车雷达, 探头后方无死角, 精准探距, 防碰防撞。

全自动冷暖空调, 自动根据需求调整室内温度。

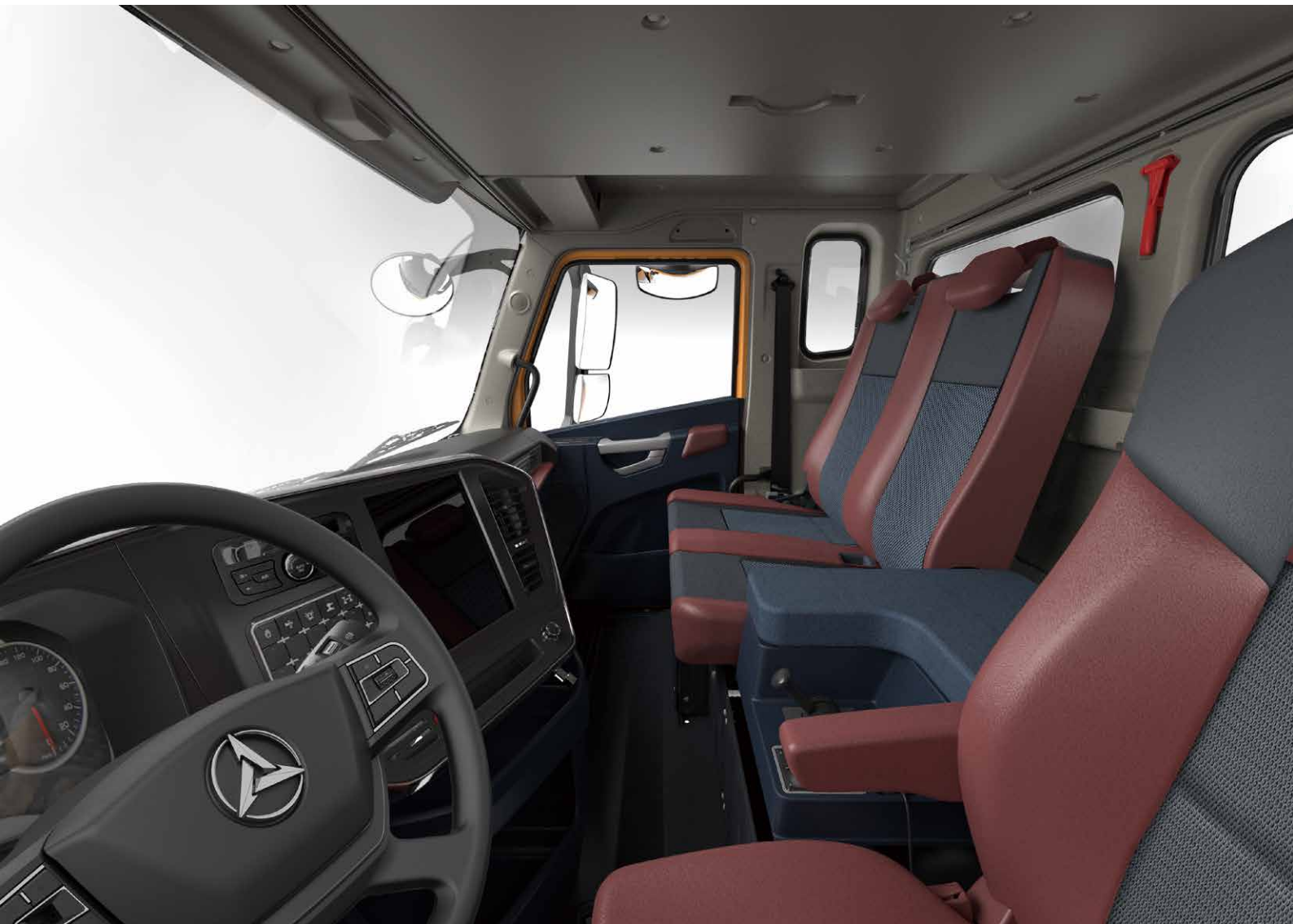



## **i-Cab - Operator's cab**

### **新两室 - 操纵室**

Seat widened by 450mm, and leg room increased by 30%.  
Cab tiltable by 0-20°, relieving cervical fatigue during large-angle and long-boom operations.  
Adjustable seat with maximum inclination of 140°, allowing the operator to lie flat and rest after work.  
Electric seat linked with armrest box, enabling multi-dimensional adjustment for enhanced comfort.  
Electronic control joysticks, making operation easier.  
Ergonomically positioned control panels, easy to reach and operate.  
70° openable front window convenient for ventilation and escape, in compliance with CE standards.  
Sliding door, more convenient for getting on/off the cab and opening/closing the door.  
Full-automatic HVAC, automatically adjusting indoor temperature as demanded.  
Double 10.1-inch display screens.

座椅加宽至 450mm,腿部活动空间较上一代增加 30%。  
操纵室可实现 0-20° 上仰变位,大角度、长臂段作业时减缓颈椎疲劳。  
可调式座椅,最大后仰 140°,操作手可平躺休息。  
电动座椅 + 扶手箱联动,多维度调节,更加舒适。  
电控操纵手柄,操作毫不费力。  
配备功能面板及左右扶手箱动作按键面板,触手可及,方便操控。  
70° 可开启式前窗,方便通风及逃生,操作室满足 CE 要求。  
手动滑移门,上下车、开关门更方便。  
全自动冷暖空调,自动根据需求调整室内温度。  
10.1 寸双屏显示。



# Overall Dimensions

## 整机尺寸

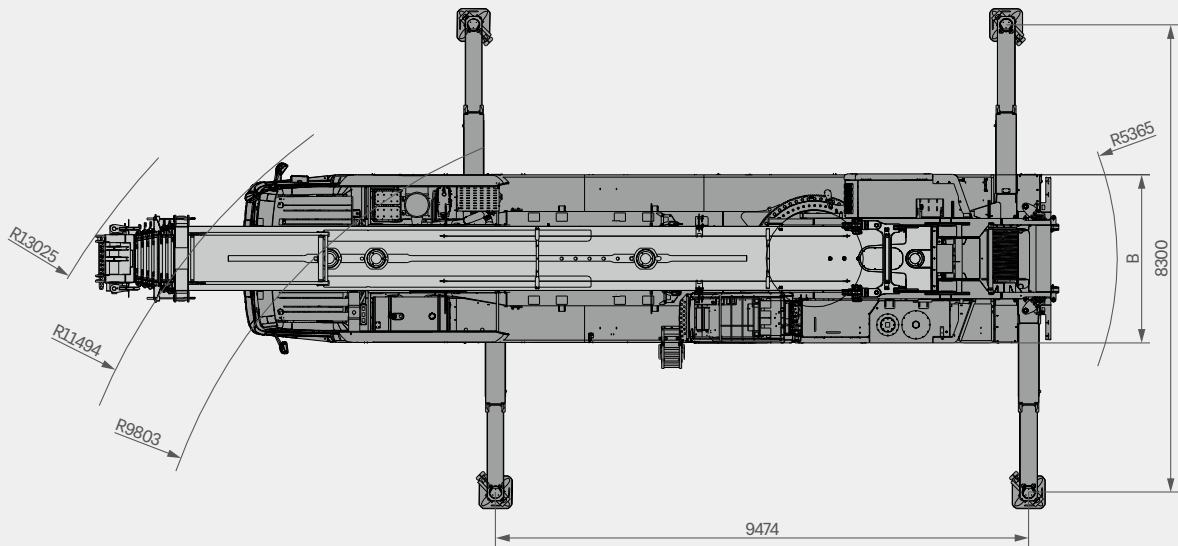
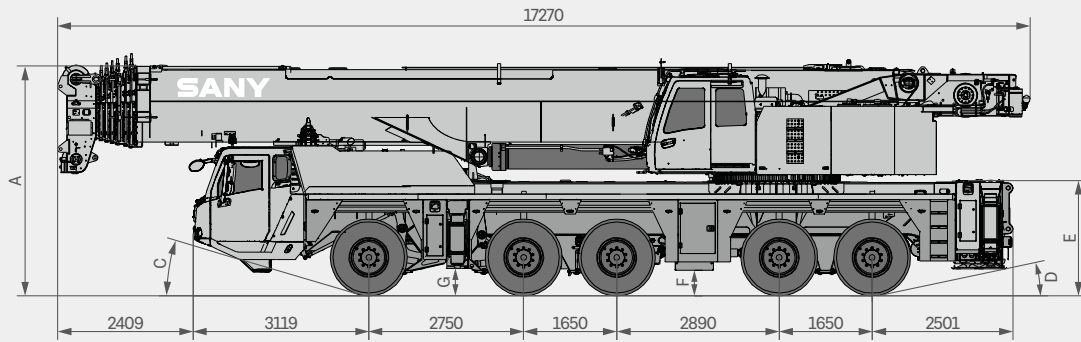

Tire size 轮胎尺寸	A	B	C	D	E	F	G
Unit 单位	mm	mm	°	°	mm	mm	mm
385	4000	3000	17	12	2050	500	276.5
445	4000	3000	19.9	13.2	2100	550	326.5

# Technical Specification

## 整机参数

CATEGORY 类型	ITEM 项目	UNIT 单位	VALUE 参数	
CAPACITY 额定起重量	Max. lifting capacity 最大起重量	t	300	
POWER (CHASSIS) 发动机参数 (下车)	Rated output power 发动机功率	kW/rpm	405/1900	
	Max. engine torque 发动机最大输出扭矩	N·m/rpm	2500/(950-1400)	
POWER (SUPERSTRUCTURE) 发动机参数 (上车)	Rated output power 发动机功率	kW/rpm	176/2300	
	Max. engine torque 发动机最大输出扭矩	N·m/rpm	860/(1200-1700)	
DIMENSIONS 尺寸参数	Overall length 整机全长	mm	17270	
	Overall width 整机全宽	mm	3000	
	Overall height 整机全高	mm	4000	
WEIGHT 重量	Gross weight 整机总质量	kg	74400	
TRAVEL 行驶参数	Max. travel speed 最高行驶速度	km	80	
	Steering radius 转弯半径	Min. steering radius (at wheels) 最小转弯半径 (轮胎处)	m	10
		Min. steering radius of boom tip 臂头转弯半径	m	13
	Wheel formula 车轮模式	-	10 × 8 × 10	
	Max. gradeability 最大爬坡度	-	58%	
	Fuel consumption per 100km 每 100 公里油耗	L	70	
MAIN PERFORMANCE 主要性能参数	Min. rated lifting radius 最小额定幅度	m	3	
	Tail slewing radius 转台尾部回转半径	m	5.36	
	Boom sections (Qty.) 臂节数	-	8	
	Boom shape 臂形状	-	Oval shape 椭圆型	
	Max. lifting moment 最大起重力矩	Basic boom 基本臂	t·m	830
		Full-extension boom 全伸主臂	t·m	341
	Boom length 臂长	Basic boom 基本臂	m	14.8
		Full-extension boom 全伸主臂	m	85
		Full-extension boom + jib 全伸主臂 + 副臂	m	117
	Outrigger span (Longitudinal × Transverse) 支腿跨距 (纵 × 横)	m	9.47 × 8.3	
Jib offset 副臂安装角度	°	0, 20, 40		
OPERATION SPEED 工作速度参数	Max. lifting speed of main winch (empty load) 主卷扬单绳最大提升速度 (空载)	m/min	125	
	Max. lifting speed of auxiliary winch (empty load) 副卷扬最大单绳提升速度 (空载)	m/min	125	
	Boom full extending/retracting time 主臂全伸缩臂时间	s	850 / 850	
	Boom full luffing up/down time 起重臂全起落幅时间	s	65 / 115	
	Slewing speed 回转速度	r/min	1.5	
AIR CONDITIONER 空调	In operator's cab 上车空调	-	Heating & Cooling 制冷、制热	
	In driver's cab 下车空调	-	Heating & Cooling 制冷、制热	

# Technical Specification

## 整机参数



Hook 吊钩

Rated load 额载 /t	Number of sheaves 滑轮数量	Rope rate 倍率	Hook weight/kg 吊钩重量
160 (double eyes 双钩头) ○	9	19	2065
80 (double eyes 双钩头) ●	3	7	695
32 (single eye 单钩头) ○	1	3	479
12.5 ●	-	1	270

● Standard 标配    ○ Optional 选配

# Crane Introduction

## 整机介绍

Carrier 下车

### Driver's cab 驾驶室

- All new 312# cab independently developed by Sany. It is of new steel structure, enabling high damping and sealing performance. It is configured with outward opening doors on both sides, air-suspension driver seat and passenger's seat, adjustable steering wheel, wide-angle rearview mirror, comfortable driver seat headrest, antifogging fan, HVAC, stereo radio, and a complete set of controls and instruments, creating a more comfortable, safe and user-friendly driving environment.
- 三一 312 新款驾驶室，自主开发新型钢结构，减震性和封闭性优良，两侧外开式车门，配备气动悬置的驾驶座与副驾座、可调整式的转向盘、大视野后视镜、配有头枕的舒适驾驶椅、防雾扇、冷暖空调，立体收音机等装配，控制仪器和仪表齐全，更加舒适、安全、人性化。

### Carrier frame 车架

- Designed and manufactured by Sany, it is anti-torsion box structure welded by fine-grained high-strength steel plates with strong bearing capacity.
- 三一设计、制造，由细晶粒高强度钢板焊接而成的防扭转箱形结构，承载能力强。

### Engine 发动机

- Model: WEICHAI WP13.550E62 supercharged and intercooled diesel, conforming to BS IV emission standard.
- Output power: 405kW/1900rpm.
- Max. torque: 2500N·m/(950-1400)rpm.
- Fuel reservoir capacity: 550L.
- 型式：潍柴 WP13.550E62 发动机，增压中冷、柴油发动机。
- 额定功率：405kW/1900rpm。
- 最大扭矩：2500N·m/950-1400rpm。
- 燃料箱容量：550L。

### Transmission 变速箱

- FAST AMT with 12 speeds forward and 2 speeds reverse.
- 力士特手自一体变速箱，12 个前进档，2 个倒档。

### Axle 车桥

- HanDe axles are adopted, with all axles steered, and axles 1, 2, 4 and 5 driven. Axles 1 and 2 are equipped with linkage-feedback hydraulic power steering system, and axles 3, 4 and 5 are equipped with electro-hydraulic steering system, providing steering control assist and several special steering modes for option, and ensuring nimble steering and flexible control.
- 汉德车桥，全桥转向，1、2、4、5 桥驱动。1、2 桥采用杆系反馈的液压助力转向系统，3、4、5 桥采用电液控制转向，可进行速度控制的辅助及可选择的特殊转向模式，转向轻便，操控灵活。

### Suspension system 悬挂

- All axles adopt height-adjustable hydro-pneumatic suspension with hydraulic lockout. The suspension stroke is 145mm, and has such modes including suspension, rigid locking, automatic leveling, whole vehicle lifting/lowering to adapt to various harsh working conditions and road surfaces, ensuring good NVH and lateral stability, and making the driving more comfortable.
- 全部车桥悬架装置均为高度可调带液压闭锁的油气悬架装置。悬挂高度可上下 145mm 调节，具有悬挂、刚性锁定、自动调平、整车升降等模式，能适用各种恶劣工况和路面，保证车辆行驶的平顺性和侧稳定性，驾驶舒适。

### Steering 转向系统

- Servo power steering gear, dual-circuit hydraulic power steering system with emergency steering pump.
- 6 steering modes: 1) on-road steer (default); 2) all-wheel steer; 3) crab; 4) reduced swing-out steer; 5) independent rear axle steer; 6) rear axle locked steer.
- 伺服动力转向器，双回路系统液压转向装置，带有应急转向泵。
- 转向模式共 6 种：1) 公路行驶模式(默认模式)；2) 全轮转向模式；3) 蟹形模式；4) 无偏摆转向模式；5) 独立后桥转向模式；6) 后桥锁定转向模式。

### Tires 轮胎

- Techking or Advance, 385 / 445 both available for options.
- 泰凯英或者前进，385/445 轮胎均可选。

### Wheel formula 车轮模式

- 10 × 8 × 10.

### Outrigger 支腿

- H-shaped outriggers with a longitudinal and transverse span of 9.47m × 8.3m and automatic leveling function are equipped, and they are extended and retracted hydraulically at both directions.
- H 形支腿，纵、横跨距 9.47m × 8.3m，全液压力水平垂直支腿油缸伸缩。具备自动水平调节功能。

### Brake 制动系统

- Parking brake: The parking brake acts on axles 2-5 by the accumulator.
- Service brake: All wheels employ air servo brakes, forming a dual-circuit braking system. Disc brake is applied for all wheels.
- 驻车制动：由蓄压器驱动作用在第二至第五桥上；
- 行车制动：所有轮子均用空气伺服制动器，双回路制动系统，所有车轮均装有盘式制动器。

### Electrical system 电气系统

- Advanced data bus system, 24V DC power supply, and 2 battery packs with a single capacity of 180Ah are provided, allowing for power cutoff of chassis.
- The chassis adopts CAN bus system, multi-functional centralized display system with low power consumption, and LCD screen with contrast adjustable.
- 先进数据总线系统，24V 直流电源，2 组蓄电池组，每组 180AH，可实现下车电源切断；
- 底盘采用 CAN 总线系统，多功能的集中显示系统，功率消耗小；采用 LCD 液晶显示，对比度可调整。

# Crane Introduction

## 整机介绍

### Operator's cab 操纵室

- All new 312# cab developed by Sany, 0°~20° tiltable, it adopts the corrosion-resistant steel plate, and is equipped with full coverage softening interior trim, panoramic skylight, adjustable seat and other user-friendly designs, making operation more comfortable and easier. The LMI display is configured to realize the coordination of the console and the operation display system, so that all working condition data can be clear at a glance.
- 三一 312 新款操纵室。0°~20° 可变角度，采用耐腐蚀钢板，配置全覆盖软化内饰、全景式天窗、可调式座椅等人性化设计，操作更舒适、轻松。配置主、辅显示屏，实现主控台与操作显示系统有机结合，使吊装作业的全部工况数据一目了然。

### Engine 发动机

- Model: WEICHAH WP6G240 diesel.
- Output power: 176kW/2300rpm.
- Max. torque: 860N·m/(1200-1700)rpm.
- Fuel reservoir capacity: 400L.
- 潍柴 WP6G240 发动机。额定功率 176kW/2300 rpm，最大扭矩 860N.m/(1200-1700) rpm。上车燃油箱容积 400L。

### Boom & telescoping system 伸缩系统

- Boom: 8-section boom of oval cross section made of fine-grained high strength steel plate, with a full-extension length of 85m.
- Jib: 22m fixed jib is offered as standard, offsettable at 0°/20°/40°. Optional jib is up to 36m in total.
- Telescopic mechanism: The inter-independent hydraulic telescopic mechanism allows for a full extension/retraction time down to 850s, more efficient, safe and reliable.
- 主臂：8 节臂，主臂全伸长 85m，由 1100MPa 细晶粒高强度钢制成，椭圆形截面。
- 副臂：标配 22m，可选至 36m。0°/20°/40° 机械变幅。
- 伸缩机构：独立液压驱动伸缩，全伸及全缩时间 850 秒，高效安全可靠。

### Hoist 起升系统

- The main winch adopts an electro proportional variable piston motor, providing good hoisting inching mobility and stability.
- 主卷扬采用电比例变量柱塞泵马达，卷扬微动性、平稳性好。

### Luffing system 变幅系统

- The passive luffing down system is more energy saving. The single cylinder + front hinged support arrangement makes the luffing more labor-saving and improves the stressing condition of the boom; an electro proportionally controlled balance valve is adopted.
- 自重落幅，更加节能。采用单油缸，前铰支布置，变幅更省力且起重臂受力得到改善；采用电比例控制平衡阀。

### Slewing platform 转台结构

- Independently designed by Sany, it is made of fine grained high-strength steel plates, with optimized structure.
- 三一自主设计，结构更优化，由细晶粒高强度钢制成。

### Control system 控制系统

- The crane is electronically controlled through the LMI system (PLC control); two multi-directional joysticks can return to the neutral position automatically; the movement of the crane is adjusted by regulating the hydraulic pump, and the speed is adjusted by regulating the speed of the engine.
- 通过力矩限制器系统对起重车进行电控（PLC控制）；两个多方向手柄，可自动复位；通过调节液压泵来调节吊车的运动。通过调节发动机的速度来调节速度。

### Slewing 回转系统

- The slewing system is applied with quality piston pump, and supports 360° rotation at a speed of 0~1.5r/min; the electro proportional closed type hydraulic circuit and electro proportional pedals are applied. Emergency braking available.
- 高品质柱塞主油泵，360° 回转，回转速度 0~1.5r/min；采用电比例闭式液压回路，电比例踏板，可实现紧急制动。

### Hydraulics 液压系统

- Key hydraulic components including main pump, slewing pump, main valve, winch motor and balance valve are of high quality, ensuring the stability and reliability of the hydraulic system; the accurate parameter matching further improves the operation performance.
- Electro proportional variable displacement piston pump is applied, and the pump displacement is adjusted in real-time by changing the opening of electric control joy, realizing high-precision flow control and reducing the energy consumption.
- Innovative dual-pump shunt/confluence main valve enables higher speed in case of single motion and better maneuverability in case of combined motions.
- Passive compensated luffing down is adopted, ensuring better inching movement and stability.
- Single-cylinder pin telescoping system is applied for the boom.
- The slewing system is of closed type, and the flow rate and the flowing direction are changed by adjusting the variable pump swash plate, providing better inching mobility and stability.
- 采用高品质的主油泵、回转泵、主阀、卷扬马达、平衡阀等关键液压元件，保证液压系统稳定、可靠；通过精确的参数匹配，使操作性能更加优越；采用电比例变量柱塞泵，通过电控手柄开度的变化，实时调节油泵排量，实现高精度流量控制，作业时无能量损耗；采用自主研发的双泵合/分流主阀，单动作双泵合流效率更高，组合动作双泵分流操控性更好。
- 采用自重落幅补偿液压系统，落幅微动性、平稳性更优越。
- 主臂伸缩采用单缸插销伸缩系统。
- 回转为闭式系统，通过调节变量泵斜盘的角度来改变流量及方向，微动性优越、回转平稳。

### Counterweight 配重

- Combined counterweights are applied, see combination chart. The counterweights can be self-loaded and unloaded via remote control.
- 组合式配重，详见组合图表。无线遥控实现配重自拆装。

### Safety equipment 安全装置

- LMI: The load moment indicator is developed by using the mechanics analysis method based on the hoisting mechanical model, and the rated hoisting accuracy is controlled within  $\pm 5\%$  through online empty-load calibration, enabling all-round protection for the hoisting operations; in case of overloading operations, the system will send an alarm automatically to guarantee safe operations.
- Hydraulic balance valve, overflow valve, two-way hydraulic lock and other elements provided for the hydraulic system, ensuring stability and reliability of the hydraulic system.
- The 3rd wrap indicator of main winch to prevent rollover of wire rope.
- A2B limit switch mounted at tip of boom and jib to prevent over-hoisting of the wire rope.
- Anemometer mounted at tip of boom to check if the wind speed is out of the allowable operating range of the crane.
- 力矩限制器：采用分析力学方法，建立了基于吊重力学模型的力矩限制器计算系统，通过在线空载标定，额定吊重精度达到  $\pm 5\%$ ，全方位保护吊载作业；超载作业时，系统自动报警提示，为操纵作业提供安全保障。
- 液压系统配置液压平衡阀、溢流阀、双向液压锁等元件，实现液压系统稳定可靠。
- 主卷扬配置三圈保护器，防止钢丝绳过放。
- 主副臂臂端配置高度限位器，防止钢丝绳过卷。
- 臂端装有风速仪，检测高空风速是否超过可作业允许范围。

# Counterweight Combinations

## 配重组合

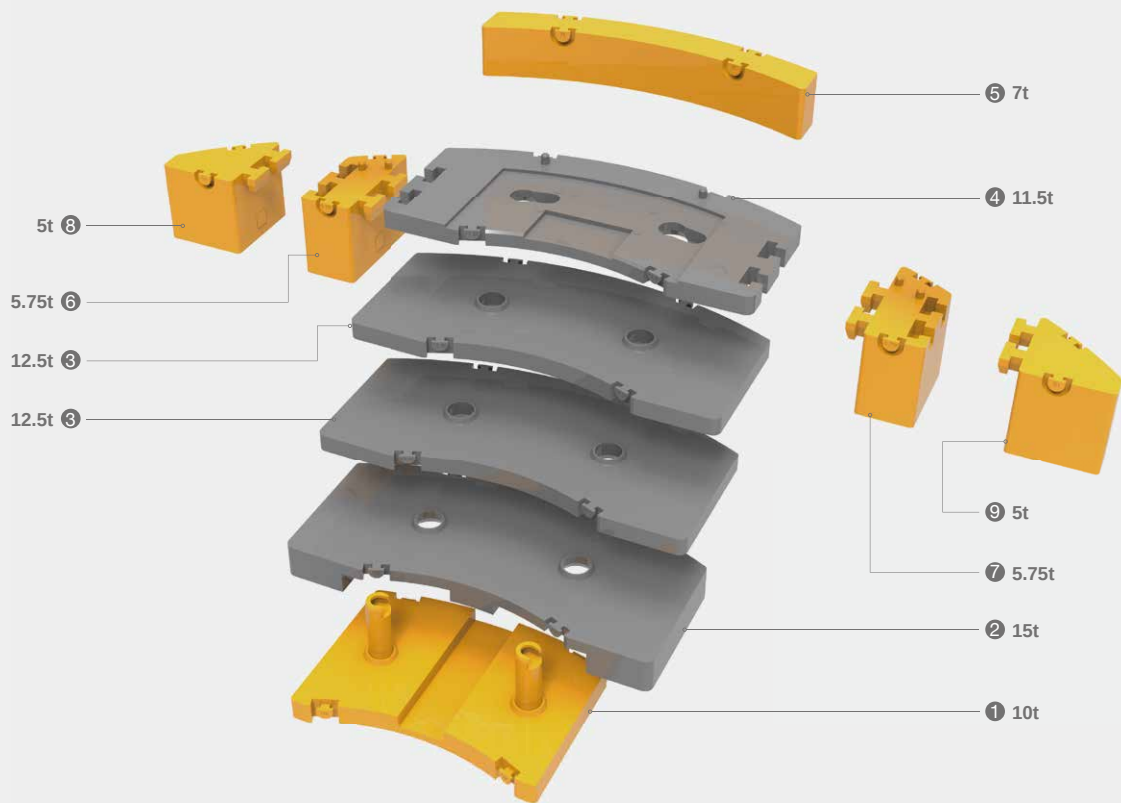
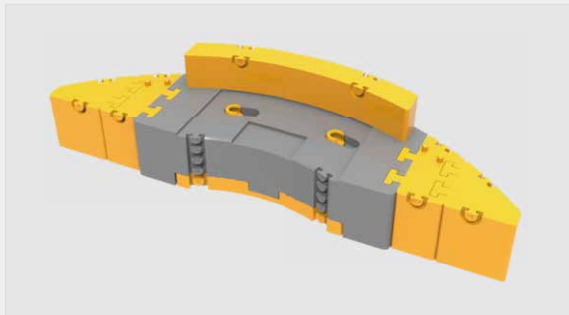

Total weight (t) 总重量	①	②	③	④	⑤	⑥	⑦	⑧	⑨
	10t	15t	12.5t × 2	11.5t	7t	5.75t	5.75t	5t	5t
10	•								
25	•	•							
37.5	•	•	•						
50	•	•	•						
61.5	•	•	•	•					
73	•	•	•	•		•	•		
80	•	•	•	•	•	•	•		
90	•	•	•	•	•	•	•	•	•

90t full counterweight provides eight combinations. Self assembly and disassembly require no assisting crane.  
全配重 90t, 8 种不同组合, 可自装卸, 无需辅助吊。

# Jib Combinations

## 副臂组合

### Boom extension with fixed jib

主臂延伸节 + 固定副臂

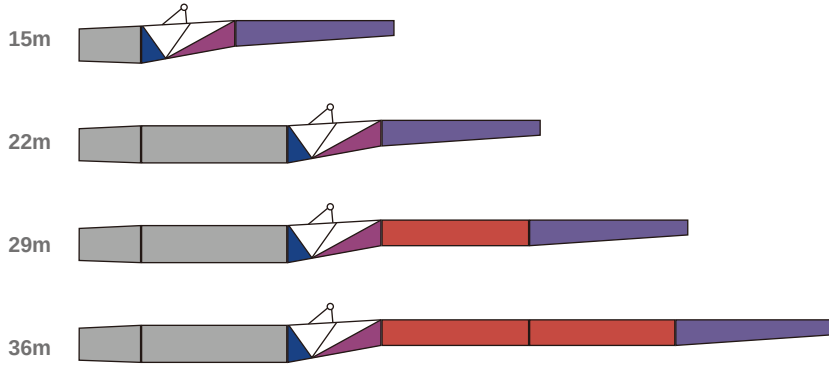

### Boom extension with fixed jib (for superlift configuration)

主臂延伸节 + 固定副臂(超起工况)

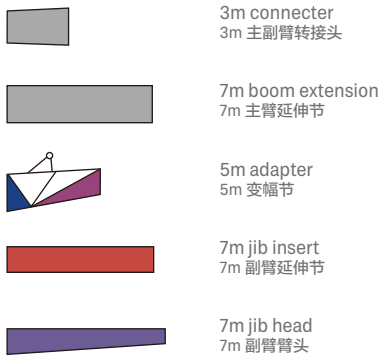
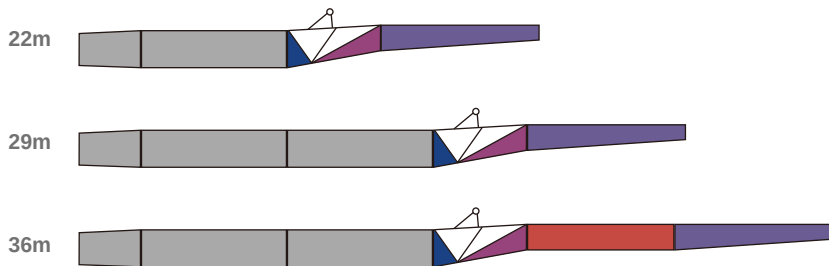

# Transport Solutions

## 带载行驶

### Various traveling modes available

On-road travel: axle load  $\leq 13t$  with boom sections 4-8 removed.

On-site travel: all boom sections carried, 1/2/3 axle load  $\leq 17t$ , 4/5 axle load  $< 13t$ .

### 提供多种带载行驶方案

公路行驶: 拆 4-8 节臂, 轴荷  $\leq 13t$ 。

工地转场: 不拆主臂, 1/2/3 轴荷  $\leq 17t$ , 4/5 轴荷  $< 13t$ 。

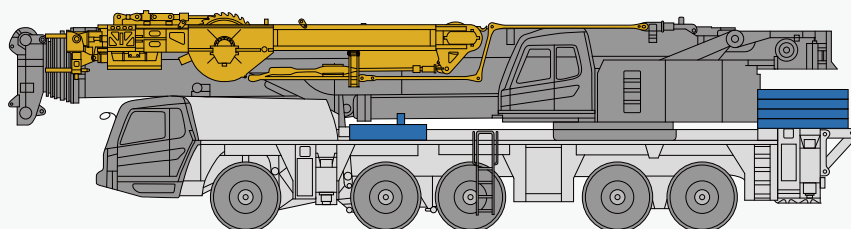
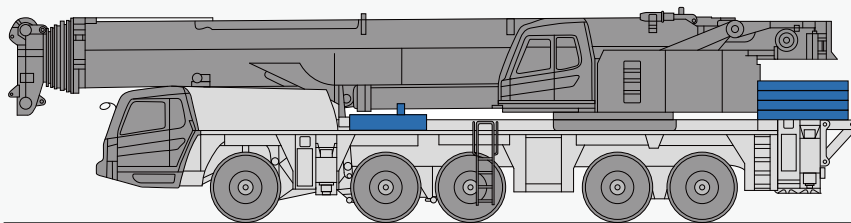
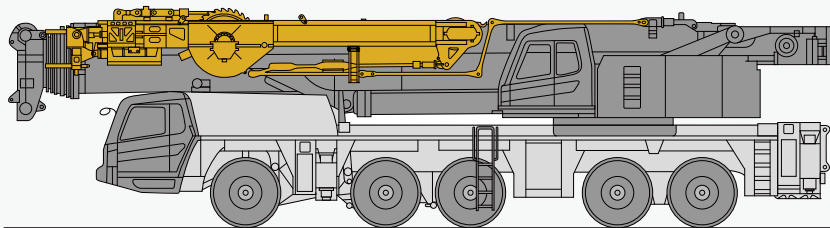

# Working Conditions & Code Description

## 工况组合及工况代码说明

- T - Telescopic boom 主臂
- S - Superlift device 超起
- J - Fixed jib 固定副臂
- E - Boom extension 主臂延伸节

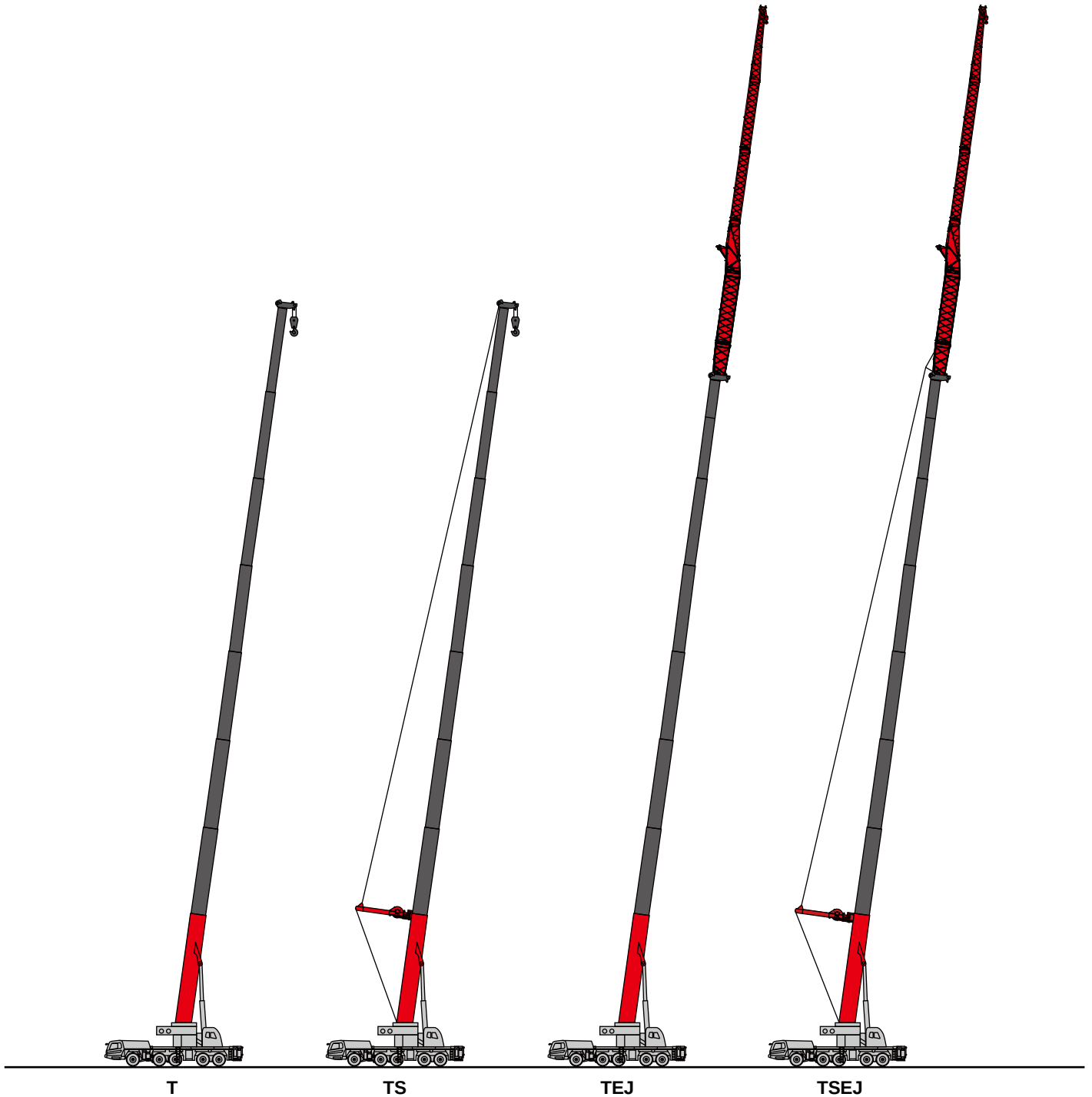

# Operating Range - T

起升高度曲线 - 主臂

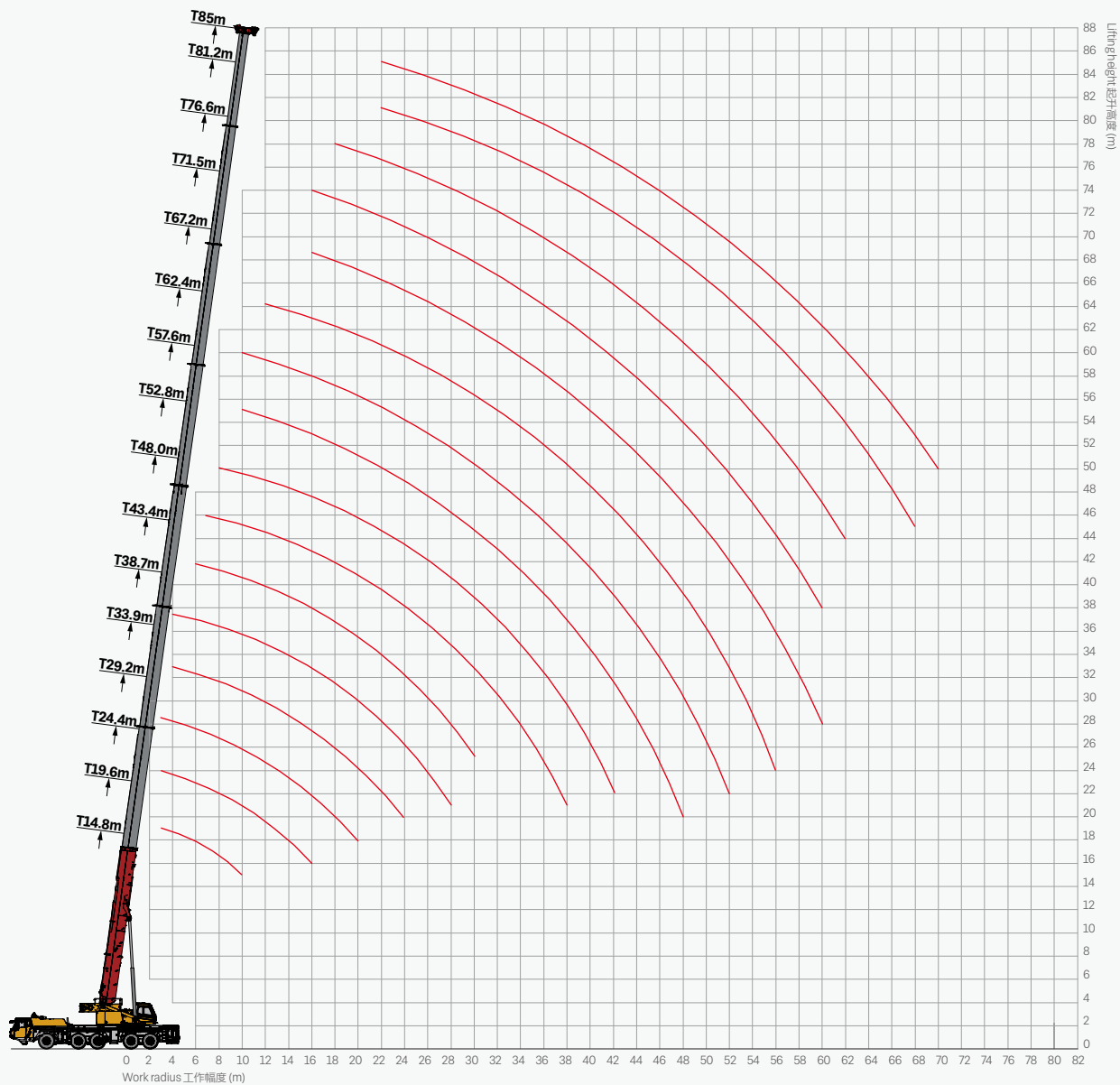

# Load Chart - T

## 性能表 - 主臂

Unit: metric ton



	14.8	19.6	24.4	29.2	33.9	38.7	43.4	48.0	52.8	57.6	62.4	67.2	71.9	76.6	81.2	85	
3	300.0	147.0	141.0	126.0													3
3.5	165.0	145.0	141.0	126.0													3.5
4	156.0	140.0	136.0	126.0	111.0												4
4.5	150.0	135.0	129.0	126.0	111.0												4.5
5	140.0	128.0	123.0	120.8	111.0	101.0											5
6	128.0	115.0	111.0	110.3	101.0	95.0											6
7	108.1	103.0	101.0	98.7	84.2	81.9	75.4										7
8	103.8	92.9	96.7	90.3	78.2	76.9	72.7										8
9	88.5	85.5	84.5	83.0	73.4	72.0	67.2	55.0									9
10	78.6	77.3	76.2	76.7	72.7	66.3	63.5	55.0	49.2	43.1							10
12		68.0	64.2	61.8	59.8	60.6	59.7	50.4	47.2	40.7	33.9						12
14		57.3	52.5	52.5	50.8	55.5	55.0	47.5	43.5	38.9	32.5						14
16		48.2	44.0	46.4	45.1	48.3	49.5	44.6	40.1	36.1	29.7	26.6	20.8				16
18			38.2	38.4	39.2	40.2	41.4	40.8	35.6	33.0	29.1	24.9	20.6	14.5			18
20			32.3	32.4	33.1	34.1	35.2	36.4	31.8	29.9	28.1	23.2	20.2	13.8			20
22				27.8	28.3	29.3	30.3	31.5	29.7	27.3	26.0	23.1	20.1	13.1	12.0	9.4	22
24				24.0	24.6	25.4	26.5	27.5	26.4	24.8	24.3	21.5	19.3	12.7	12.0	9.2	24
26					21.4	22.2	23.2	24.2	23.2	22.4	22.7	20.2	18.4	12.4	11.4	9.0	26
28					18.7	19.6	20.5	21.5	20.4	20.1	20.1	18.9	17.4	12.3	11.4	9.0	28
30						17.3	18.2	19.1	18.1	17.8	17.8	17.6	16.4	11.6	11.3	8.9	30
32							16.3	17.2	16.1	15.8	15.8	16.0	15.3	11.0	10.8	8.8	32
34							14.5	15.4	14.4	14.1	14.1	14.2	14.5	10.5	10.4	8.4	34
36							13.0	13.9	12.8	12.6	12.6	12.8	13.1	10.5	10.0	8.1	36
38							11.7	12.5	11.6	11.3	11.2	11.4	11.7	10.1	9.5	7.7	38
40								11.4	10.3	10.1	10.0	10.3	10.5	9.5	9.0	7.4	40
42								10.3	9.3	9.0	9.0	9.2	9.4	9.1	8.8	7.2	42
44									8.4	8.0	8.0	8.2	8.4	8.5	8.7	7.1	44
46									7.6	7.2	7.1	7.3	7.6	7.6	8.2	7.0	46
48									6.7	6.4	6.4	6.6	6.7	6.9	7.4	6.7	48
50										5.7	5.6	5.8	6.0	6.2	6.7	6.5	50
52										5.0	4.9	5.1	5.3	5.6	6.1	6.1	52
54											4.3	4.4	4.7	4.9	5.4	5.4	54
56											3.7	3.8	4.1	4.4	4.9	4.9	56
58												3.3	3.5	3.8	4.3	4.3	58
60												2.8	3.0	3.3	3.8	3.8	60
62												2.3		2.9	3.3	3.3	62
64															2.9	2.9	64
66															2.5	2.5	66
68															2.1	2.1	68
70																1.7	70
	14	14	14	13	11	10	8	6	5	4	4	3	2	2	2	2	
	2#	0	0	46	46	46	46	46	92	92	92	92	92	92	92	100	2#
	3#	0	46	46	46	46	46	46	46	92	92	92	92	92	92	100	3#
	4#	0	0	0	46	46	46	46	46	46	92	92	92	92	92	100	4#
	5#	0	0	0	0	46	46	46	46	46	46	92	92	92	92	100	5#
	6#	0	0	0	0	0	46	46	46	46	46	46	92	92	92	100	6#
	7#	0	0	0	0	0	0	46	46	46	46	46	46	92	92	92	7#
	8#	0	0	0	0	0	0	0	46	46	46	46	46	46	92	92	8#

**Remark:**

1. Ratings listed are the max. capacity when the crane is set up in a level condition on solid ground or surface.

2. Ratings above are calculated with hooks and lifting slings considered as part of load.

备注:

1、起重性能表中给定数值是在平整坚固的地面上，整机调平状态下起重机的额定起重量。

2、起重性能表中工作幅度是指吊载后的实际幅度。

# Operating Range - TS

起升高度曲线 - 主臂 + 超起

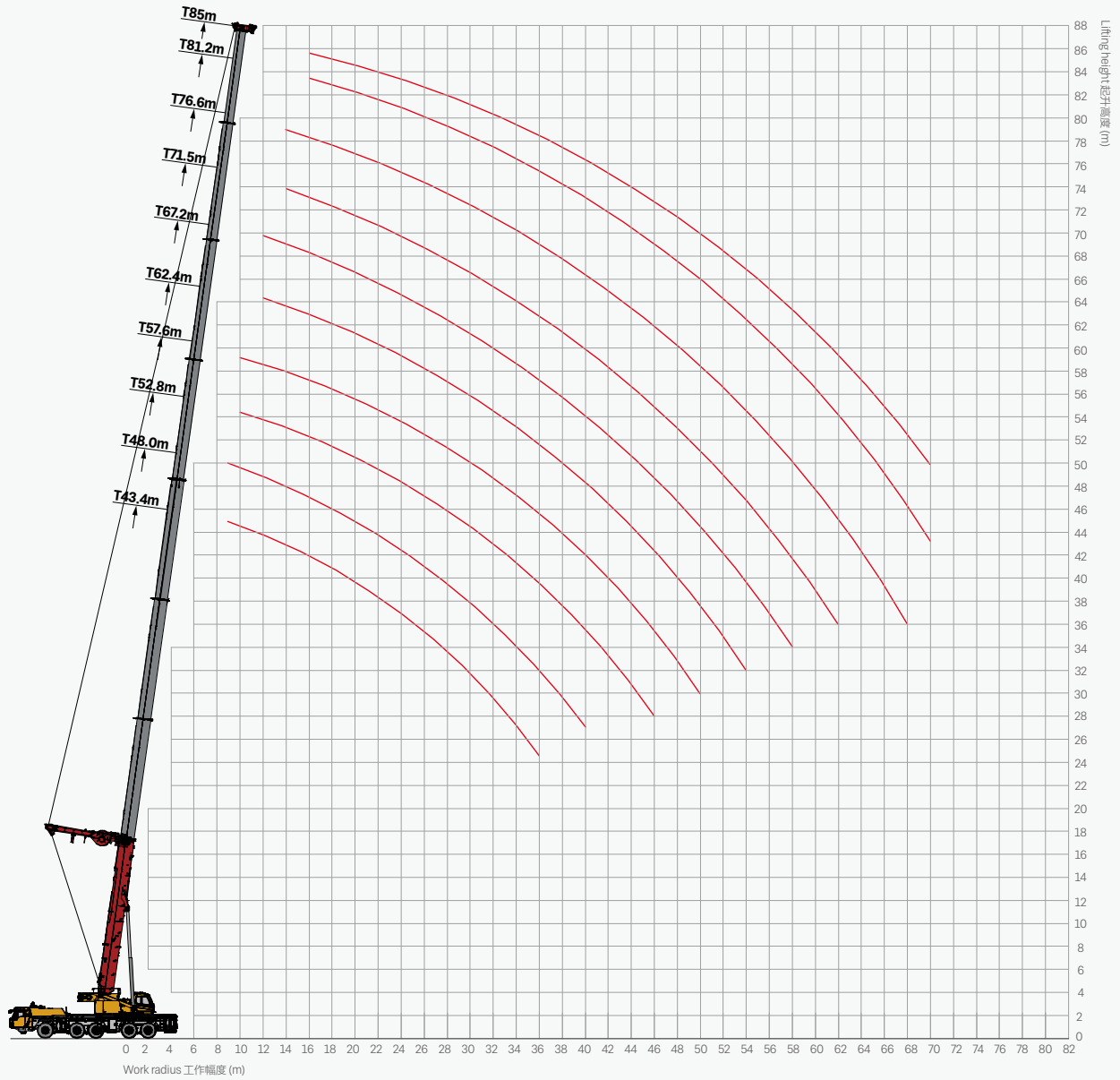

# Load Chart - TS

## 性能表 - 主臂 + 超起

Unit: metric ton

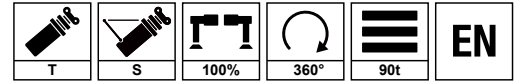

	43.4	48	52.8	57.6	62.4	67.2	71.9	76.6	81.2	85	
9	70.0	61.5									9
10	61.7	61.0	57.0	51.9							10
12	60.0	60.0	53.5	49.4	41.6	37.5					12
14	55.3	53.3	51.5	47.3	38.6	35.4	31.8	26.9			14
16	50.6	48.9	46.8	43.6	38.0	33.3	30.4	26.0	21.8	17.3	16
18	42.0	42.6	40.5	40.6	36.4	31.5	28.9	25.0	21.2	16.9	18
20	35.4	36.7	35.1	35.2	34.3	30.3	27.5	24.1	20.6	16.4	20
22	30.2	31.5	30.7	30.6	30.5	28.1	26.0	23.1	20.6	16.2	22
24	25.9	27.4	26.5	26.4	26.6	26.5	25.5	22.0	19.9	16.1	24
26	22.5	23.9	23.0	22.9	23.1	23.6	23.7	21.4	19.1	15.6	26
28	19.6	20.9	20.1	20.0	20.2	20.5	21.0	20.2	18.2	15.1	28
30	17.1	18.4	17.6	17.5	17.7	18.1	18.5	18.3	17.4	14.7	30
32	15.0	16.3	15.5	15.4	15.6	15.9	16.3	17.0	16.1	14.0	32
34	13.2	14.3	13.6	13.5	13.7	14.1	14.5	15.1	15.0	13.4	34
36	11.5	12.8	12.0	11.9	12.1	12.4	12.8	13.4	13.8	12.7	36
38		11.3	10.6	10.5	10.6	10.9	11.3	12.0	12.6	12.2	38
40		10.0	9.3	9.2	9.4	9.7	10.0	10.7	11.3	11.4	40
42			8.2	8.0	8.2	8.5	8.9	9.6	10.1	10.2	42
44			7.0	7.0	7.2	7.5	7.8	8.4	9.1	9.2	44
46			6.1	6.0	6.2	6.5	6.9	7.5	8.1	8.2	46
48				5.1	5.2	5.6	6.0	6.7	7.2	7.3	48
50				4.2	4.4	4.8	5.1	5.8	6.4	6.5	50
52					3.6	4.0	4.4	5.0	5.6	5.7	52
54					2.9	3.3	3.6	4.3	4.9	5.0	54
56						2.6	3.0	3.6	4.2	4.3	56
58						2.0	2.4	3.0	3.6	3.7	58
60							1.8	2.4	3.0	3.1	60
62							1.3	1.9	2.5	2.6	62
64								1.4	2.0	2.1	64
66									1.5	1.6	66
68										1.2	68
	7	6	6	5	4	4	3	3	2	2	
2#	46	46	92	92	92	92	92	92	92	100	2#
3#	46	46	46	92	92	92	92	92	92	100	3#
4#	46	46	46	46	92	92	92	92	92	100	4#
5#	46	46	46	46	46	92	92	92	92	100	5#
6#	46	46	46	46	46	46	92	92	92	100	6#
7#	46	46	46	46	46	46	46	92	92	92	7#
8#	0	46	46	46	46	46	46	46	92	92	8#

# Operating Range - TEJ

起升高度曲线 - 副臂(主臂76.6m+副臂36m)

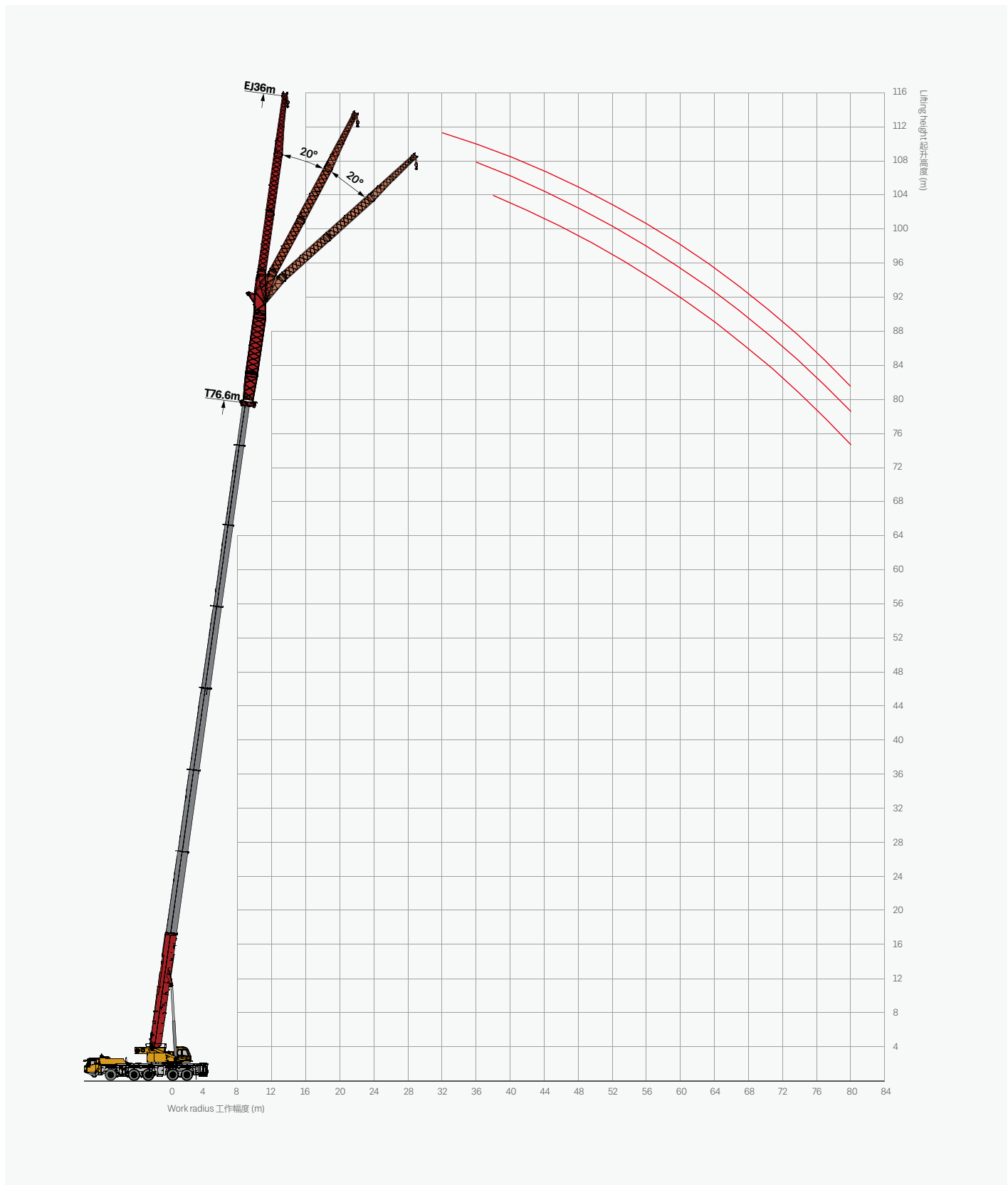

# Operating Range - TEJ

起升高度曲线 - 副臂(主臂81.2m+副臂29m)

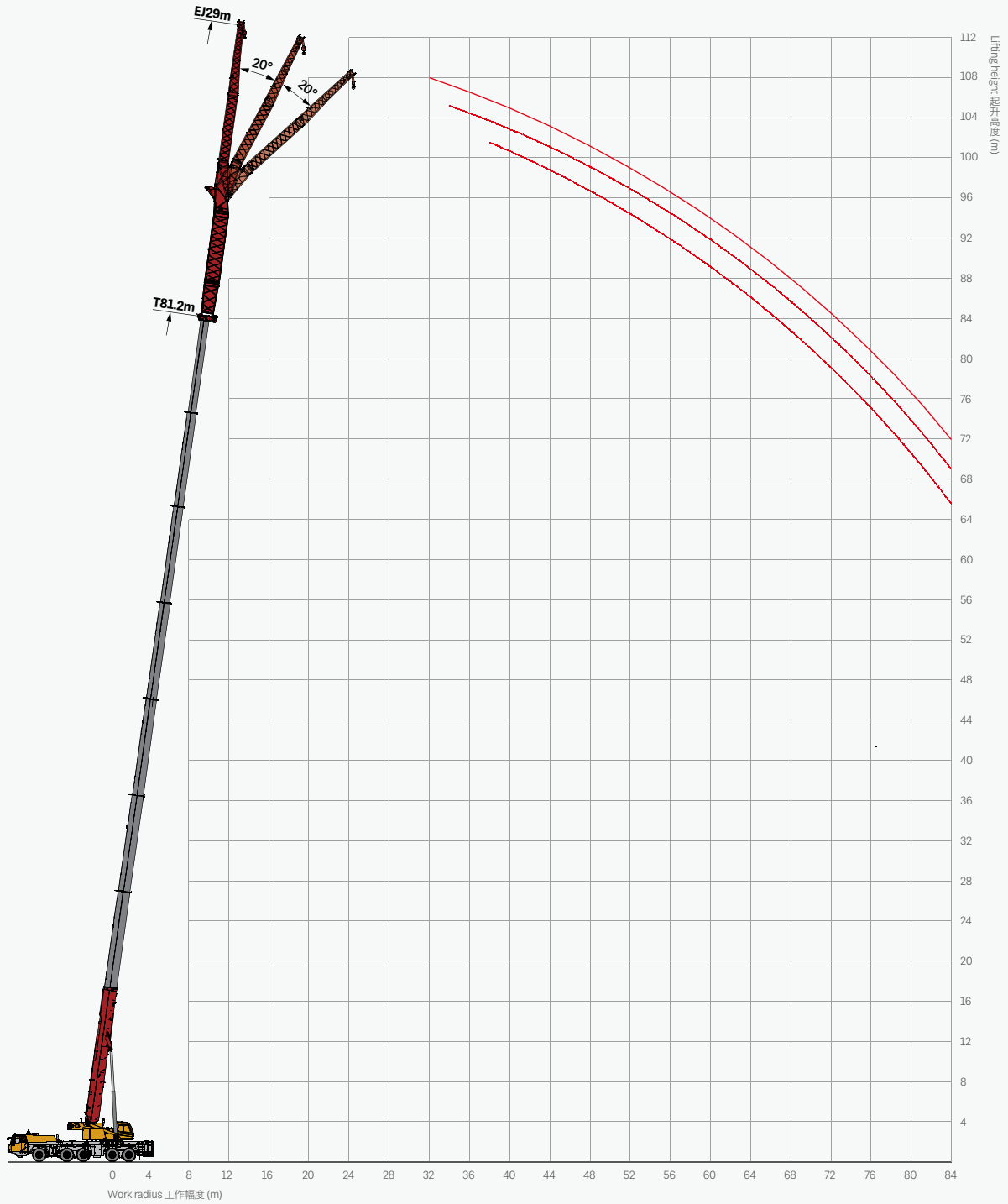

# Load Chart - TEJ

## 性能表 - 副臂

Unit: metric ton

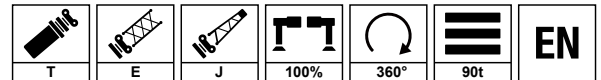

m	76.6m			81.2m			76.6m			81.2m			m
	15m			15m			22m			22m			
	0°	20°	40°	0°	20°	40°	0°	20°	40°	0°	20°	40°	
24	7.3	6.1	5.0	5.5									24
26	7.2	5.9	4.9	5.5	4.8		6.5						26
28	6.9	5.7	4.8	5.5	4.7	4.1	6.5	5.6		5.3			28
30	6.7	5.5	4.8	5.5	4.6	4.0	6.5	5.5	4.8	5.3	4.8		30
32	6.5	5.3	4.7	5.5	4.5	3.9	6.4	5.5	4.7	5.2	4.8	4.2	32
34	6.3	5.1	4.6	5.3	4.4	3.8	6.2	5.3	4.6	5.2	4.7	4.2	34
36	6.1	4.9	4.5	5.1	4.3	3.7	6.1	5.0	4.5	5.1	4.6	4.1	36
38	5.9	4.8	4.4	4.9	4.2	3.7	5.9	4.9	4.3	5.0	4.6	4.0	38
40	5.7	4.8	4.3	4.8	4.1	3.6	5.8	4.8	4.2	4.9	4.4	3.9	40
42	5.5	4.7	4.2	4.6	4.0	3.6	5.6	4.6	4.2	4.8	4.3	3.8	42
44	5.3	4.6	4.1	4.4	3.9	3.5	5.3	4.6	4.1	4.7	4.2	3.7	44
46	5.1	4.5	4.0	4.2	3.8	3.5	5.0	4.4	4.0	4.6	4.0	3.6	46
48	4.9	4.4	4.0	4.0	3.7	3.4	4.7	4.3	3.9	4.4	4.0	3.5	48
50	4.8	4.3	3.9	3.8	3.6	3.4	4.3	4.1	3.7	4.1	3.9	3.5	50
52	4.6	4.2	3.9	3.6	3.5	3.3	4.0	4.0	3.7	3.9	3.7	3.4	52
54	4.4	4.1	3.8	3.4	3.3	3.2	3.8	3.7	3.6	3.7	3.5	3.3	54
56	4.2	4.0	3.8	3.3	3.2	3.1	3.6	3.5	3.5	3.5	3.4	3.2	56
58	3.6	3.9	3.7	3.2	3.1	3.0	3.4	3.4	3.3	3.4	3.2	3.0	58
60	3.1	3.4	3.5	3.1	3.0	2.9	3.3	3.2	3.1	3.2	3.0	2.8	60
62	2.6	2.8	3.0	3.0	2.9	2.9	2.9	2.9	3.0	2.9	2.8	2.7	62
64	2.1	2.4	2.5	2.5	2.7	2.8	2.4	2.6	2.7	2.7	2.7	2.5	64
66	1.7	1.9	2.0	2.1	2.3	2.4	2.0	2.2	2.3	2.3	2.5	2.4	66
68	1.3	1.5		1.7	1.9	2.0	1.6	1.8	1.9	1.9	2.1	2.2	68
70	1.0			1.3	1.5	1.5	1.2	1.4	1.5	1.5	1.7	1.8	70
72				1.0	1.1	1.2		1.0	1.1	1.1	1.3	1.4	72
74											1.0	1.0	74
	1	1	1	1	1	1	1	1	1	1	1	1	
	2#	92		92			92			92			2#
	3#	92		92			92			92			3#
	4#	92		92			92			92			4#
	5#	92		92			92			92			5#
	6#	92		92			92			92			6#
	7#	92		92			92			92			7#
	8#	46		92			46			92			8#

# Load Chart - TEJ

## 性能表 - 副臂

Unit: metric ton

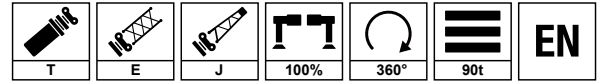

m	76.6m			81.2m			76.6m			m
	29m			29m			36m			
	0°	20°	40°	0°	20°	40°	0°	20°	40°	
28	4.7									28
30	4.6									30
32	4.4	3.6		4.0			3.2			32
34	4.2	3.5	2.8	3.9	3.2		3.2			34
36	4.1	3.4	2.8	3.7	3.2		3.2	2.8		36
38	4.0	3.3	2.7	3.6	3.1	2.6	3.1	2.8	2.4	38
40	3.9	3.2	2.7	3.5	2.9	2.6	3.1	2.8	2.4	40
42	3.8	3.1	2.6	3.4	2.9	2.5	3.1	2.7	2.3	42
44	3.6	3.0	2.5	3.4	2.8	2.4	3.1	2.6	2.3	44
46	3.4	2.9	2.4	3.3	2.7	2.3	2.9	2.4	2.2	46
48	3.4	2.8	2.3	3.1	2.6	2.2	2.8	2.4	2.2	48
50	3.3	2.8	2.2	3.0	2.5	2.2	2.7	2.3	2.1	50
52	3.2	2.7	2.2	2.9	2.4	2.2	2.6	2.2	2.1	52
54	3.0	2.6	2.2	2.8	2.4	2.1	2.5	2.2	2.0	54
56	2.9	2.5	2.2	2.8	2.3	2.1	2.4	2.1	1.9	56
58	2.8	2.4	2.1	2.7	2.2	2.0	2.3	2.1	1.8	58
60	2.8	2.3	2.0	2.6	2.2	1.9	2.2	2.0	1.8	60
62	2.7	2.2	1.9	2.5	2.1	1.8	2.2	1.9	1.7	62
64	2.6	2.2	1.9	2.4	2.0	1.8	2.0	1.8	1.7	64
66	2.1	2.1	1.8	2.3	2.0	1.7	1.8	1.7	1.6	66
68	1.7	2.1	1.8	2.0	1.9	1.7	1.7	1.6	1.5	68
70	1.3	1.7	1.8	1.6	1.8	1.7	1.4	1.5	1.5	70
72	1.0	1.3	1.5	1.2	1.6	1.6	1.0	1.5	1.5	72
74		1.0	1.1	1.0	1.2	1.4		1.2	1.3	74
76					1.0	1.0			1.1	76
	1	1	1	1	1	1	1	1	1	
2#		92			92			92		2#
3#		92			92			92		3#
4#		92			92			92		4#
5#		92			92			92		5#
6#		92			92			92		6#
7#		92			92			92		7#
8#		46			92			46		8#

# Operating Range - TSEJ

起升高度曲线 - 超起(主臂76.6m+副臂36m)

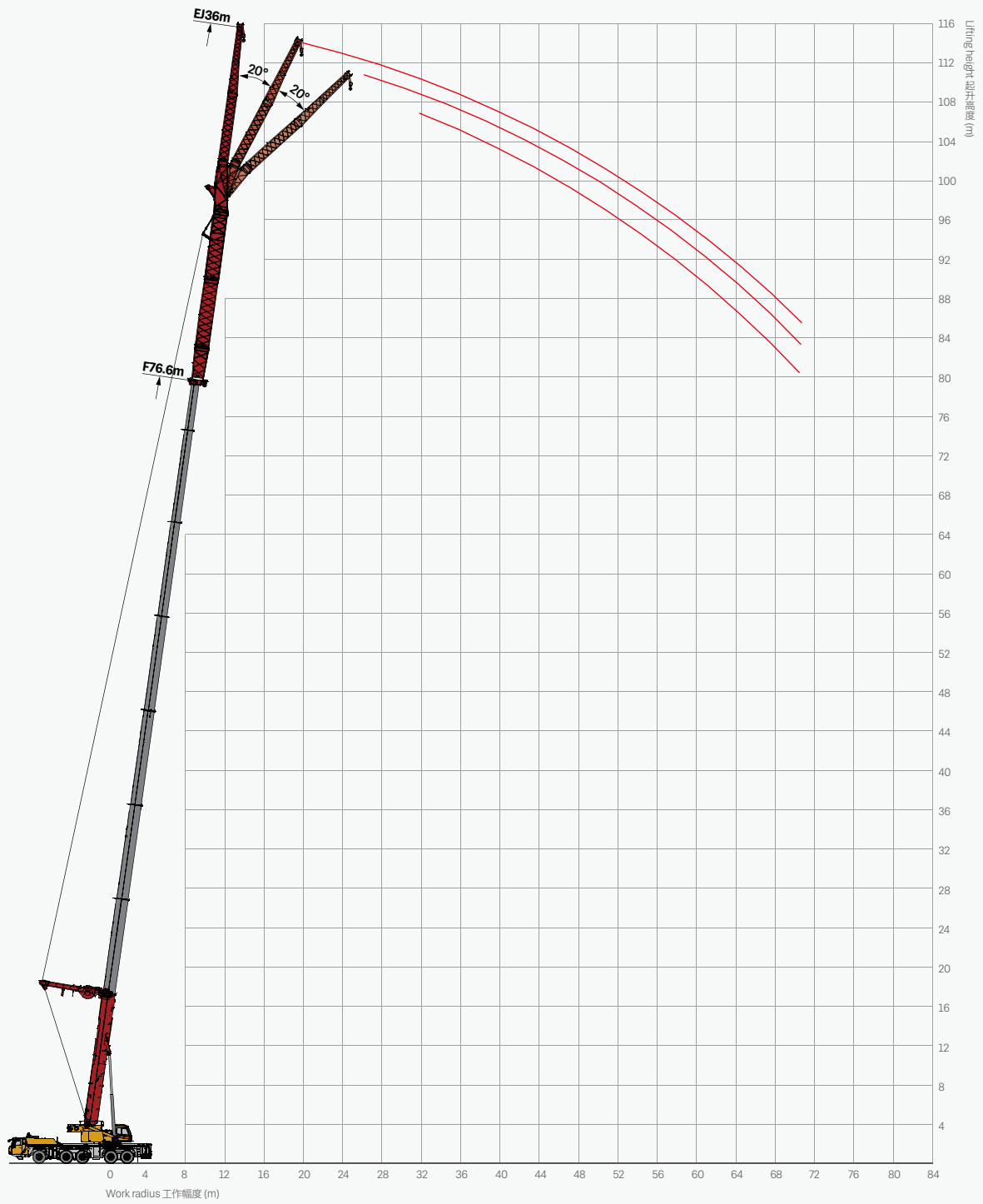

# Operating Range - TSEJ

起升高度曲线 - 超起(主臂81.2m+副臂36m)

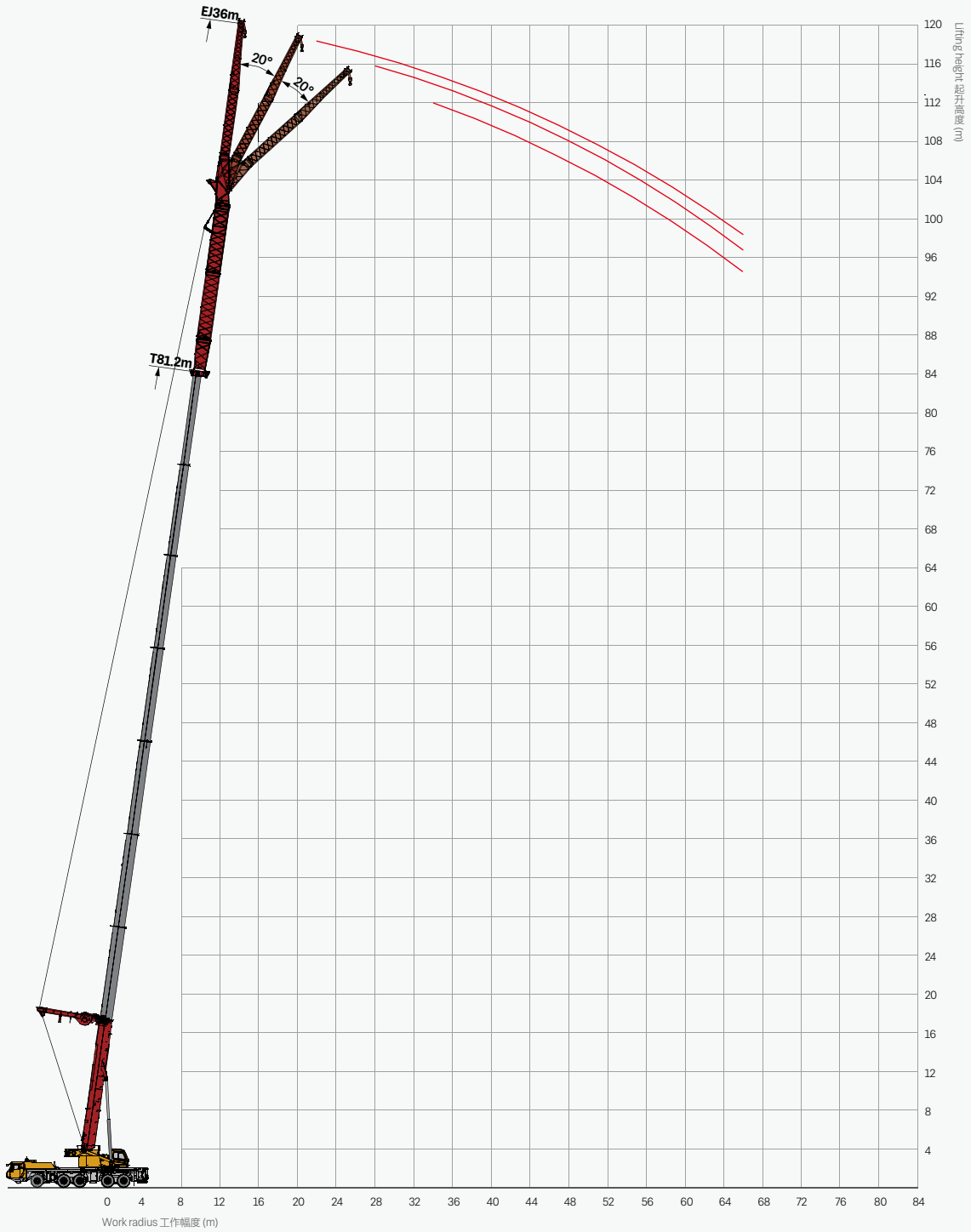

# Load Chart - TSEJ

性能表 - 超起 + 主臂延伸节 + 副臂

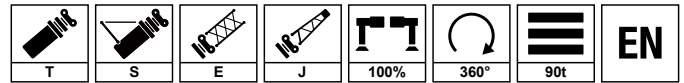

Unit: metric ton

m	67.2m+22m			71.5m			76.6m			81.2m			m
	22m			22m			22m			22m			
	0°	20°	40°	0°	20°	40°	0°	20°	40°	0°	20°	40°	
14	16.7			15.7									14
16	16.0			14.9			14.0			12.2			16
18	15.3	13.0		14.5	13.2		13.1			11.3			18
20	14.5	12.7		13.9	12.7		12.3	11.6		9.9	9.9		20
22	13.8	12.3	8.8	13.2	12.2	8.8	12.0	10.8		9.5	9.5		22
24	13.3	12.2	8.6	12.7	11.4	8.8	11.6	10.4	8.8	9.0	8.6	7.2	24
26	12.6	11.4	8.5	12.2	11.0	8.6	11.1	9.9	8.6	8.6	8.2	6.8	26
28	12.2	11.0	8.2	11.4	10.5	8.4	10.7	9.5	8.3	8.2	7.9	6.3	28
30	11.4	10.5	7.9	11.0	10.2	8.1	10.3	9.1	7.9	7.9	7.7	5.9	30
32	11.0	9.8	7.7	10.5	9.8	7.9	9.9	8.6	7.7	7.7	7.4	5.0	32
34	10.5	9.2	7.6	10.2	9.4	7.7	9.5	7.8	7.3	7.4	7.2	4.5	34
36	9.9	8.2	7.4	9.8	8.5	7.4	9.1	7.0	7.0	7.2	7.0	4.3	36
38	9.2	7.3	7.2	9.4	7.6	7.0	8.6	6.3	6.3	7.0	6.8	4.1	38
40	8.2	6.6	6.5	8.5	6.8	6.7	7.8	5.6	5.7	6.8	6.4	3.8	40
42	7.3	5.8	5.9	7.6	6.0	6.1	7.0	5.0	5.1	6.4	5.9	3.6	42
44	6.6	5.1	5.1	6.8	5.3	5.4	6.3	4.4	4.5	5.9	5.3	3.4	44
46	5.8	4.5	4.5	6.0	4.8	4.8	5.6	3.9	4.1	5.3	4.8	3.2	46
48	5.1	4.0	4.1	5.3	4.1	4.1	5.0	3.4	3.6	4.8	4.2	2.9	48
50	4.5	3.4	3.6	4.8	3.7	3.6	4.4	3.0	3.2	4.2	3.7	2.7	50
52	4.0	3.0	3.2	4.1	3.2	3.2	3.9	2.5	2.7	3.7	3.2	2.5	52
54	3.4	2.5	2.7	3.7	2.7	2.7	3.4	2.3	2.4	3.2	2.7	2.3	54
56	3.0	2.3	2.3	3.2	2.4	2.4	3.0	2.2	2.3	2.7	2.3	2.3	56
58	2.5	2.1	1.8	2.7	2.3	2.3	2.5	2.0	2.1	2.3	2.0	2.2	58
60	2.0	1.9	1.7	2.2	2.1	2.1	2.3	1.8	2.0	2.0	1.9	2.1	60
62	1.5	1.7	1.7	1.6	1.9	1.9	1.9	2.0	1.8	1.9	1.7	2.0	62
64	1.0	1.3		1.1	1.4	1.6	1.4	1.7	1.7	1.7	1.5	1.9	64
66					1.0		1.0	1.3		1.3			66
	2	2	2	2	2	2	2	1	1	1	1	1	
	2#	92		92			92			92			2#
	3#	92		92			92			92			3#
	4#	92		92			92			92			4#
	5#	92		92			92			92			5#
	6#	46		92			92			92			6#
	7#	46		46			92			92			7#
	8#	46		46			46			92			8#

# Load Chart - TSEJ

性能表 - 超起 + 主臂延伸节 + 副臂

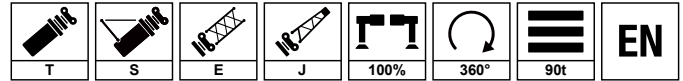

Unit: metric ton

m	76.6m			81.2m			76.6m			81.2m			m	
	29m			29m			36m			36m				
	0°	20°	40°	0°	20°	40°	0°	20°	40°	0°	20°	40°		
16	10.4												16	
18	10.4			9.0									18	
20	9.9	8.6		8.7			7.2						20	
22	9.6	8.4		8.6	8.6		6.8			5.9			22	
24	9.4	8.1	6.8	8.2	8.2		6.3			5.9			24	
26	9.0	7.8	6.3	8.0	8.0	7.2	5.9	5.4		5.7			26	
28	8.6	7.7	5.9	7.8	7.8	7.2	5.4	5.2		5.4	5.2		28	
30	8.1	7.2	5.4	7.6	7.6	7.0	5.2	5.0		5.1	5.0		30	
32	7.7	6.8	5.0	7.3	7.3	6.8	5.0	4.9	4.3	5.0	4.7		32	
34	7.2	6.3	4.5	7.0	7.1	6.7	4.9	4.7	4.2	4.8	4.4	3.6	34	
36	6.8	5.9	4.3	6.8	6.9	6.5	4.7	4.5	4.1	4.6	4.2	3.6	36	
38	6.3	5.4	4.1	6.6	6.8	6.3	4.5	4.2	4.1	4.5	4.1	3.5	38	
40	5.9	5.0	3.8	6.1	6.3	5.9	4.2	4.1	3.8	4.3	3.8	3.4	40	
42	5.4	4.7	3.6	5.5	5.9	5.4	4.1	3.8	3.6	4.2	3.6	3.3	42	
44	5.0	4.5	3.4	5.0	5.5	5.0	3.8	3.6	3.4	4.0	3.4	3.2	44	
46	4.7	4.1	3.2	4.5	5.0	4.5	3.6	3.4	3.2	3.6	3.3	3.2	46	
48	4.5	3.6	2.9	4.1	4.5	4.1	3.4	3.2	3.1	3.3	3.2	3.2	48	
50	4.1	3.1	2.7	3.6	4.1	3.6	3.2	3.1	2.9	3.1	3.1	3.2	50	
52	3.6	2.7	2.5	3.3	3.6	3.3	3.1	2.9	2.7	2.9	3.0	2.9	52	
54	3.1	2.3	2.3	3.1	3.3	3.1	2.9	2.7	2.4	2.7	2.8	2.7	54	
56	2.7	2.0	2.3	2.7	3.1	2.7	2.7	2.4	2.3	2.6	2.6	2.5	56	
58	2.3	1.7	2.2	2.4	2.7	2.4	2.4	2.3	2.1	2.4	2.3	2.3	58	
60	2.0	1.5		2.3	2.4	2.3	2.3	2.1	1.9	2.3	2.2	2.1	60	
62	1.7			2.0	2.3	2.0	2.1	1.9	1.8	2.2	2.0	1.9	62	
64	1.5			1.8	2.0	1.8	1.9	1.8	1.7	2.1	1.8	1.8	64	
66				1.5	1.8	1.7	1.5	1.7	1.6	1.7	1.7	1.7	66	
68							1.0	1.6	1.5				68	
70								1.1	1.4				70	
	1	1	1	1	1	1	1	1	1	1	1	1		
	2#	92			92			92			92			2#
	3#	92			92			92			92			3#
	4#	92			92			92			92			4#
	5#	92			92			92			92			5#
	6#	92			92			92			92			6#
	7#	92			92			92			92			7#
	8#	46			92			46			92			8#



## SANY GROUP CRANE BU

SANY Mobile Crane Industrial Park, No.168 Jinzhou Avenue, Jinzhou Development Zone, Changsha City,  
Hunan Province, P.R. China Zip 410600  
Consulting [sanycrane@sanygroup.com](mailto:sanycrane@sanygroup.com) (Crane BU) / [crd@sany.com.cn](mailto:crd@sany.com.cn) (IHQ)  
After-sales Service 0086-400 6098 318

Reminder:

Any change in the technical parameters and configuration due to product modification or upgrade may occur without prior notice.  
The machine in the picture may include additional equipment. This brochure is for reference only, and goods in kind shall prevail.  
Copyright at SANY. No part of this brochure may be copied or used for any purpose without written approval from SANY.

© Edited in February 2023

### 三一集团起重事业部

中国湖南长沙金洲开发区金洲大道 168 号 三一汽车起重机产业园 邮编: 410600  
咨询: [sanycrane@sanygroup.com](mailto:sanycrane@sanygroup.com) (起重事业部) / [crd@sany.com.cn](mailto:crd@sany.com.cn) (国际总部)  
海外售后服务: 0086-400 6098 318

温馨提示:

由于技术不断更新, 技术参数及配置如有更改, 恕不另行通知。图中机器可能包括附加设备, 本画册仅供参考, 以实物为准。  
版权为三一所有, 未经三一书面许可, 本画册任何内容不得被复制用于任何目的。

© 2023 年 2 月版

