

# KOMATSU®

## PC200-8M0 PC200LC-8M0

**PC**  
**200**

#### HORSEPOWER

Gross: 110 kW 147 HP / 2000 min<sup>-1</sup>

Net: 103 kW 138 HP / 2000 min<sup>-1</sup>

#### OPERATING WEIGHT

PC200-8M0: 19800 – 20500 kg

PC200LC-8M0: 20700 – 21700 kg

#### BUCKET CAPACITY

0.50 – 1.20 m<sup>3</sup>



Photos may include optional equipment.

# **WALK-AROUND**





### **ECOLOGY & ECONOMY**

- ▮ Low Fuel Consumption by Total Control of the Engine, Hydraulic and Electronic System
- ▮ Low Emission Engine
- ▮ Low Operation Noise

### **COMFORT & SAFETY**

- ▮ Large Comfortable Cab
- ▮ ROPS Cab (ISO 12117-2)
- ▮ Rear View Monitor System (Optional)

\* Information and Communication Technology

### **ICT\* & KOMTRAX**

- ▮ Large Multi-lingual High Resolution Liquid Crystal Display (LCD) Monitor
- ▮ Equipment Management Monitoring System
- ▮ KOMTRAX

### **MAINTENANCE & RELIABILITY**

- ▮ Easy Maintenance
- ▮ High Rigidity Work Equipment



	PC200-8M0	PC200LC-8M0
<b>HORSEPOWER</b>	Gross: 110 kW 147 HP / 2000 min <sup>-1</sup> Net: 103 kW 138 HP / 2000 min <sup>-1</sup>	110 kW 147 HP / 2000 min <sup>-1</sup> 103 kW 138 HP / 2000 min <sup>-1</sup>
<b>OPERATING WEIGHT</b>	19800 – 20500 kg	20700 – 21700 kg
<b>BUCKET CAPACITY</b>	0.50 – 1.20 m <sup>3</sup>	0.50 – 1.20 m <sup>3</sup>

# ECOLOGY & ECONOMY

## Low Fuel Consumption

The newly-developed Komatsu SAA6D107E-1 engine enables NOx emissions to be significantly reduced with the accurate multi-staged fuel injection by the engine controller. It improves total engine durability using the high-pressure fuel injection system developed specifically for construction machinery. This excavator significantly reduces hourly fuel consumption using the highly-efficient matching techniques of the engine and hydraulic unit and also provides features that promote energy-saving operations such as the E mode and ECO gauge.

## Fuel consumption

# 7% reduced

Vs. PC200-8  
Based on typical work pattern collected via KOMTRAX.  
Fuel consumption varies depending on job conditions.

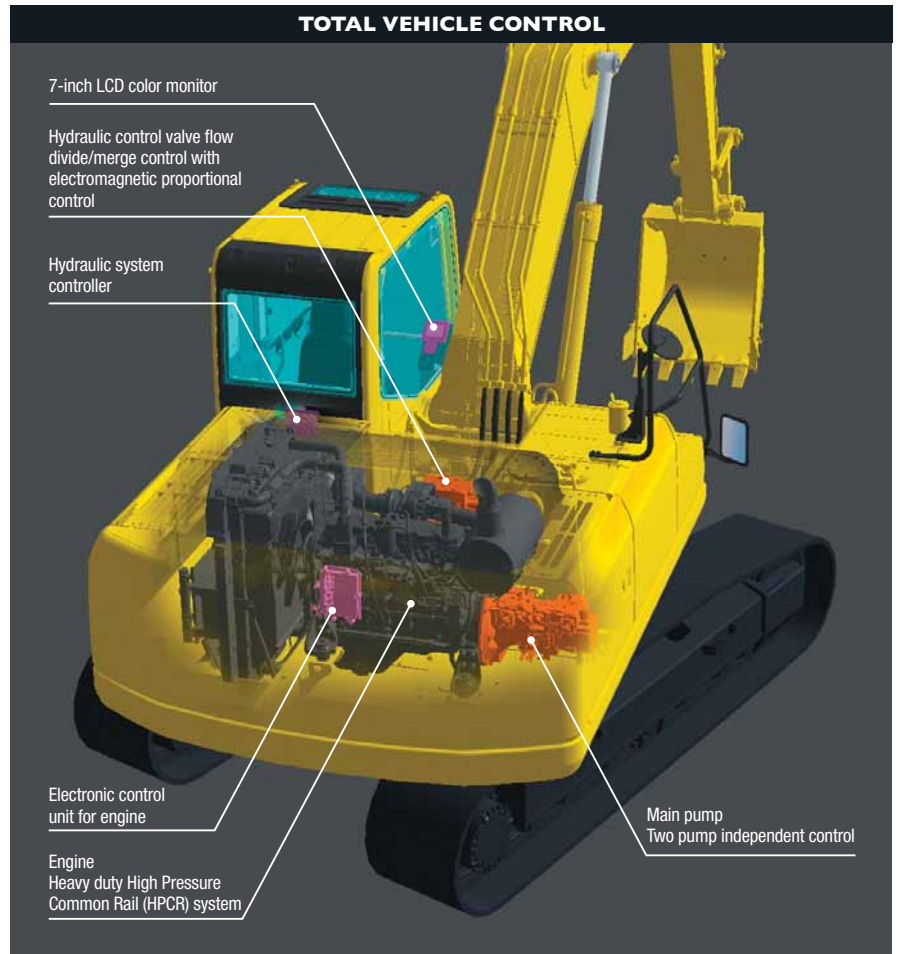

## Komatsu Technology

Komatsu develops and produces all major components, such as engines, electronics and hydraulic components, in house. With this “Komatsu Technology” and adding customer feedback, Komatsu is achieving great advancements in technology. To achieve both high levels of productivity and economical performance, Komatsu has developed the main components with a total control system. The result is a new generation of high performance and environment-friendly excavators.



### Low Emission Engine

Komatsu SAA6D107E-1 reduced NOx emission by 29% compared with the PC200-7. This engine is U.S. EPA Tier 3 and EU Stage 3A emissions equivalent.

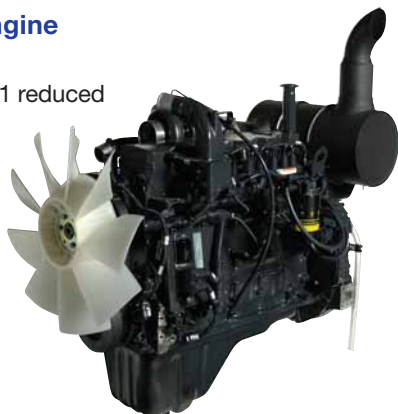

### Low Operation Noise

Enables a low noise operation using the low-noise engine and methods to cut noise at source.

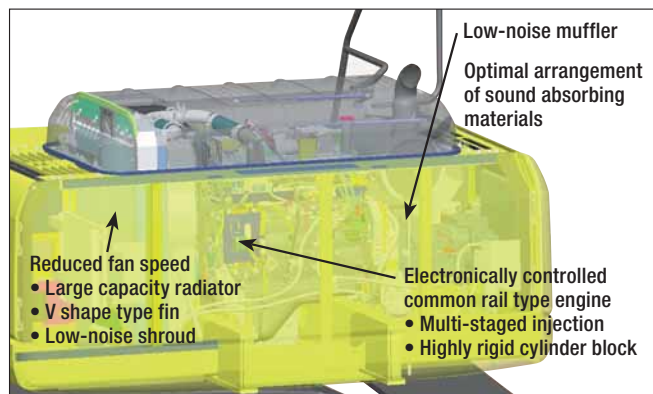

### Idling Caution

To prevent unnecessary fuel consumption, an idling caution is displayed on the monitor, if the engine idles for 5 minutes or more.



### ECO Gauge that Assists Energy-saving Operations

Equipped with the ECO gauge that can be recognized at a glance on the right of the multi-function color monitor for environment-friendly energy-saving operations. Allows focus on operation in the green range with reduced CO<sub>2</sub> emissions and efficient fuel consumption.



ECO gauge

### Working Modes Selectable

The PC200-8M0 excavator is equipped with six working modes (P, E, L, B, ATT/P and ATT/E mode). Each mode is designed to match engine speed and pump output to the application. This provides the flexibility to match equipment performance to the job at hand.

Working Mode	Application	Advantage
<b>P</b>	Power mode	<ul style="list-style-type: none"> <li>Maximum production/power</li> <li>Fast cycle times</li> </ul>
<b>E</b>	Economy mode	<ul style="list-style-type: none"> <li>Good cycle times</li> <li>Better fuel economy</li> </ul>
<b>L</b>	Lifting mode	<ul style="list-style-type: none"> <li>Suitable attachment speed</li> <li>Lifting capacity is increased 7% by raising hydraulic pressure.</li> </ul>
<b>B</b>	Breaker mode	<ul style="list-style-type: none"> <li>Optimum engine rpm, hydraulic flow</li> </ul>
<b>ATT/P</b>	Attachment Power mode	<ul style="list-style-type: none"> <li>Optimum engine rpm, hydraulic flow, 2way</li> <li>Power mode</li> </ul>
<b>ATT/E</b>	Attachment Economy mode	<ul style="list-style-type: none"> <li>Optimum engine rpm, hydraulic flow, 2way</li> <li>Economy mode</li> </ul>

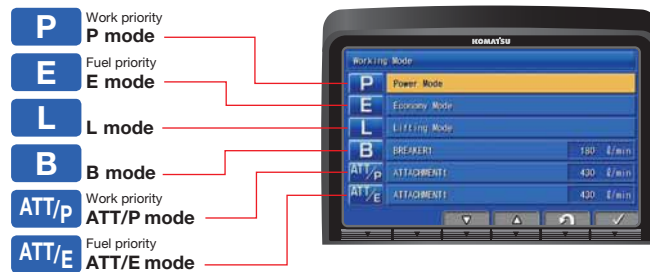

### Large Digging Force

When press the left knob switch which is called the one-touch power max. switch and when it is kept pressed, this function temporarily increases digging force for 8.5 seconds of operation.

#### Maximum arm crowd force (ISO 6015):

101 kN (10.3 t) ➔ **108 kN (11.0 t)** **7% UP**  
(with Power Max.)

#### Maximum bucket digging force (ISO 6015):

138 kN (14.1 t) ➔ **149 kN (15.2 t)** **8% UP**  
(with Power Max.)

Measured with Power Max. function, 2925 mm arm and ISO 6015 rating.

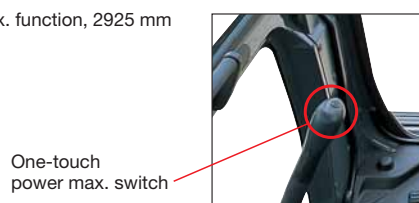

One-touch power max. switch

# COMFORT



## Low Cab Noise

The newly-designed cab is highly rigid and has excellent sound absorption ability. Thorough improvement of noise source reduction and use of low noise engine, hydraulic equipment, and air conditioner allows this machine to generate a low level of noise.

## Low Vibration with Cab Damper Mounting

PC200-8M0 uses viscous damper mounting for cab that incorporates longer stroke and the addition of a spring. The new cab damper mounting combined with high rigidity deck aids vibration reduction at operator seat.

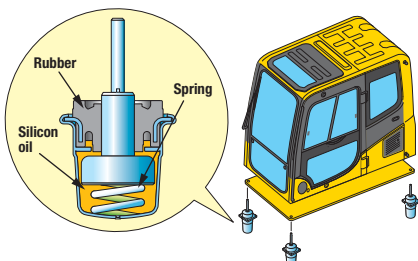

## Wide Newly-designed Cab

Newly-designed wide spacious cab includes seat with reclining backrest. The seat height and longitudinal inclination are easily adjusted using a pull-up lever. You can set the appropriate operational posture of armrest together with the console. Reclining the seat further enables you to place it into the fully flat state with the headrest attached.



## Pressurized Cab

Optional air conditioner, air filter and a higher internal air pressure minimize external dust from entering the cab.

## Automatic Air Conditioner (A/C) (Optional)

Enables you to easily and precisely set cab atmosphere with the instruments on the large LCD. The bi-level control function keeps the operator's head and feet cool and warm respectively. This improved air flow function keeps the inside of the cab comfortable throughout the year. Defroster function keeps front glass clear.

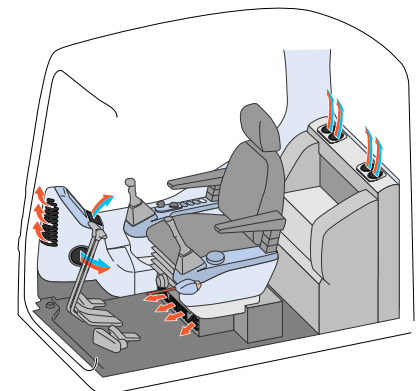

# SAFETY

## ROPS Cab

The machine is equipped with a ROPS cab that conforms to ISO 12117-2 for excavators as standard equipment. The ROPS cab has high shock-absorption performance, featuring excellent durability and impact strength. It also satisfies the requirements of OPG top guard level 1 (ISO 10262) for falling objects. Combined with the retractable seat belt, The ROPS cab protects the operator in case of tipping over and against falling objects.

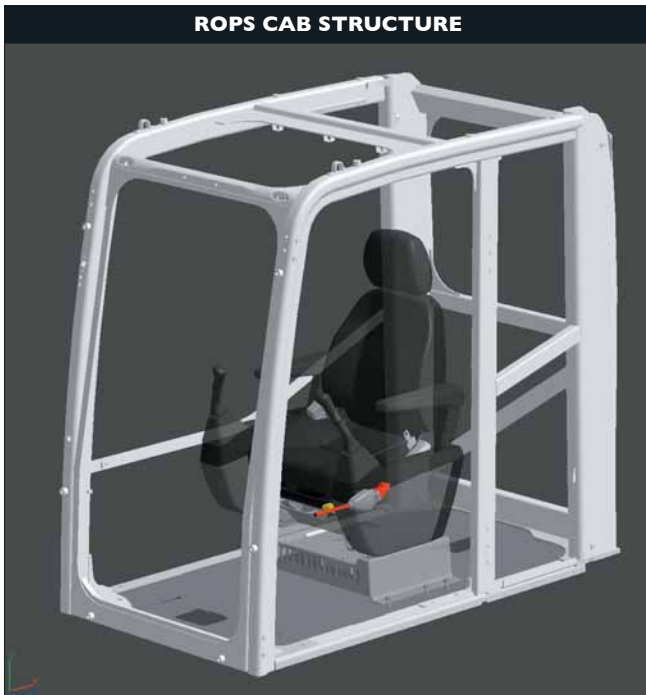

## Slip-resistant Plates

Highly durable slip-resistant plates maintain superior traction performance for the long term.



## Pump/Engine Room Partition

Pump/engine room partition prevents oil from spraying onto the engine if a hydraulic hose should burst.

## Lock Lever

Locks the hydraulic pressure to prevent unintentional movement. Neutral start function allows machine to be started only in lock position.



## Large Side-view, Rear and Sidewise Mirrors

Enlarged left-side mirror and addition of rear and side mirror allow the PC200-8M0 to meet the visibility requirements (ISO 5006).

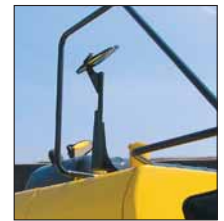

## Rear View Monitor System (Optional)

The operator can view the rear of the machine with a color monitor screen.



Rear view image on monitor

## Thermal and Fan Guards

Thermal and fan guards are placed around high-temperature parts of the engine and fan drive.





## Large Multi-lingual High Resolution LCD Monitor

A large user-friendly high resolution LCD color monitor enables safe, accurate and smooth work. Visibility and resolution are further improved compared with current 7-inch large LCD. Simple and easy to operate switches. Function keys facilitate multi-function operations. Displays data in 13 languages to globally support operators around the world.

### Indicators

- |                                  |                                   |
|----------------------------------|-----------------------------------|
| 1 Auto-decelerator               | 5 Hydraulic oil temperature gauge |
| 2 Working mode                   | 6 Fuel gauge                      |
| 3 Travel speed                   | 7 ECO gauge                       |
| 4 Engine water temperature gauge | 8 Fuel consumption gauge          |
|                                  | 9 Function switches menu          |

### Basic operation switches

- |                         |                     |
|-------------------------|---------------------|
| 1 Auto-decelerator      | 4 Buzzer cancel     |
| 2 Working mode selector | 5 Wiper             |
| 3 Traveling selector    | 6 Windshield washer |

## Supports Efficiency Improvement

The main screen displays advices for promoting energy-saving operations as needed. The operator can use the ECO guidance menu to check the operation records, ECO guidance records, average fuel consumption logs, etc.



## Equipment Management Monitoring System

### Monitor function

Controller monitors engine oil level, coolant temperature, battery charge air clogging, etc. If the controller finds any abnormality, it is displayed on the LCD.



### Maintenance function

The monitor informs replacement time of oil and filters on the LCD when the replacement interval is reached.



### Trouble data memory function

Monitor stores abnormalities for effective troubleshooting.



Assists Customer's Equipment Management and Contributes to Fuel Cost Cutting

Equipment Management Support

KOMTRAX terminal installed on your machine collects and sends information such as machine location, working record, machine conditions, etc. using wireless communication. You can review the KOMTRAX data remotely via the online application. KOMTRAX not only gives you the informations on your machine, but also the convenience of managing your fleet on the Web.



Location

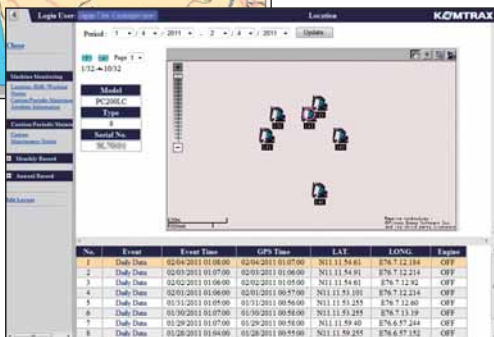

Movement generated position

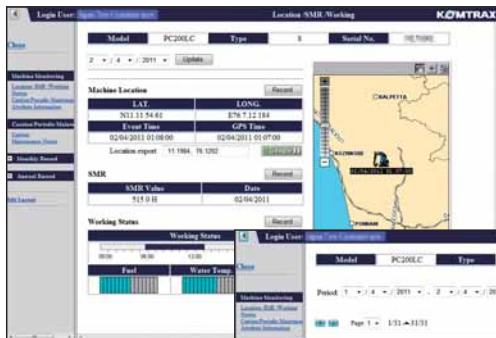

Operation map



Monthly status summary

Energy-saving Operation Support Report

KOMTRAX can provide various useful information which includes the energy-saving operation support report created based on the operating information of your machine such as fuel consumption and idle time.

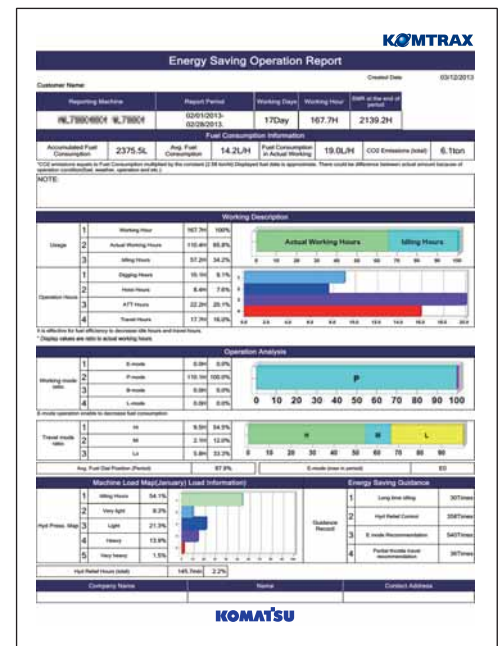

Image

# MAINTENANCE

## Side-by-side Cooling

Since radiator, aftercooler and oil cooler are arranged in parallel, it is easy to clean, remove and install them. Radiator, aftercooler, and oil cooler made of aluminum have high cooling efficiency and are easily recycled.



## Equipped with the Fuel Pre-filter (With Water Separator)

Removes water and contaminants in the fuel to prevent fuel problems. (With built-in priming pump)



## Washable Cab Floormat

The PC200-8M0's cab floormat is easy to keep clean. The gently inclined surface has a flanged floormat and drainage holes to facilitate runoff.



## Easy Access to Engine Oil Filter and Fuel Drain Valve

Engine oil filter and fuel drain valve are remote mounted to improve accessibility.



## Equipped with the Drain Valve as Standard

Prevents clothes and the ground from becoming contaminated due to oil leakage when replacing the engine oil.



## Large-capacity Fuel Tank and Rustproof Treatment

400-liter high-capacity fuel tank. Effective corrosion resistance using rust-proof treatment.

## Sloping Track Frame

Prevents dirt and sand from accumulating and allows easy mud removal.

## Gas Assisted Engine Hood Damper Cylinders

The engine hood can be easily opened and closed with the assistance of the gas assisted engine hood damper cylinders.



## Long-life Oil, Filter

Uses high-performance filtering materials and long-life oil. Extends the oil and filter replacement interval.

Engine oil & Engine oil filter	every <b>500</b> hours
Hydraulic oil	every <b>5000</b> hours
Hydraulic oil filter	every <b>1000</b> hours

## A/C Filter (Optional)

The A/C filter is removed and installed without the use of tools facilitating filter maintenance.



Internal A/C filter

External A/C filter

## Long Work Equipment Greasing Interval (Optional)

High quality bushings and resin shims are optionally available for work equipment pins excluding bucket, extending greasing interval to 500 hours.

# RELIABILITY

## High Rigidity Work Equipment

Boom and arms are constructed of thick plates of high tensile strength steel. In addition, these structures are designed with large cross-sectional areas and generous use of castings. The result is working attachments that exhibit long term durability and high resistance to bending and torsional stress.

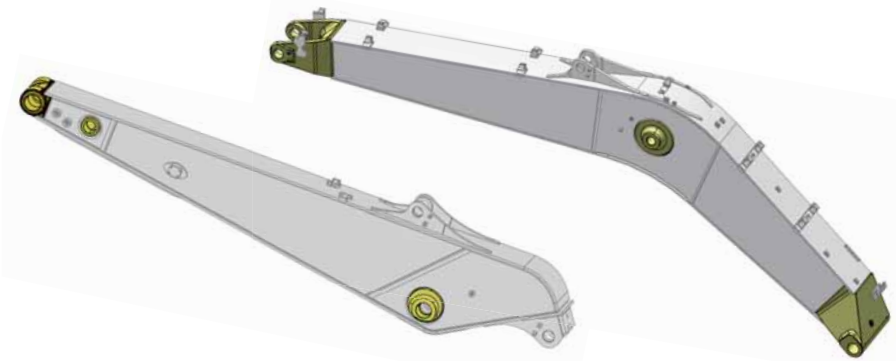

## Sturdy Frame Structure

The revolving frame, center frame and undercarriage are designed by using the most advanced three-dimensional CAD and Finite Element Method (FEM) analysis technology.

## Highly Reliable Electronic Devices

Exclusively designed electronic devices have passed severe testing.

- Controller
- Sensors
- Connectors
- Heat resistant wiring

## Grease Sealed Track

PC200-8M0 uses grease sealed tracks for extended undercarriage life.

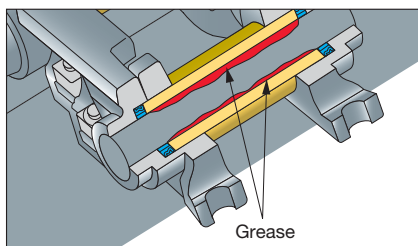

## Track Link with Strut

PC200-8M0 uses track links with strut, providing superb durability.

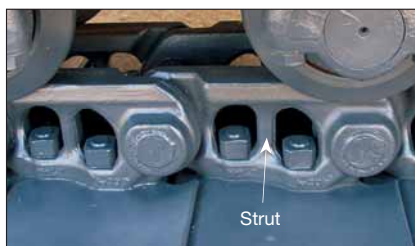

## Reliable Components

All of the major machine components, such as engine, hydraulic pumps, hydraulic motors and control valves are exclusively designed and manufactured by Komatsu.

# OPTIONS

- Cab front full height guard level 1 (ISO 10262)



- OPG top guard level 2 (ISO 10262)



- Additional front lights
- Rain visor



- Air pre-cleaner

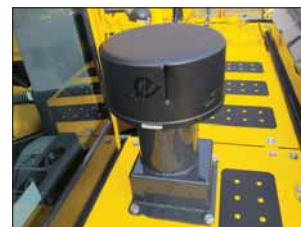

- Strengthened track frame undercover



- Sun visor



- Seat, suspension



# KOMATSU BRAND BUCKET

## KOMATSU Brand Bucket for General Purpose with Wide Bucket Width

### Me Bucket

- Low resistant excavation
- High productivity
- High durability
- High fuel efficiency

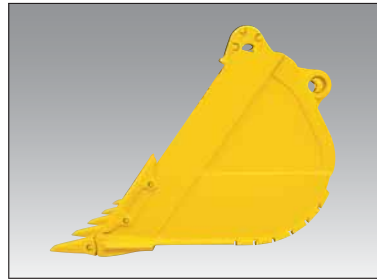

Conventional



Me Bucket

### Category and Feature

Category	Load / Wear / Soil (Application)	Image
<b>Light Duty</b> LD	<p><b>Load</b> Machine power remains low during the majority of the work. No impact load.</p> <p><b>Wear</b> Material is not abrasive.</p> <p><b>Soil</b> Dirt, loam and clay.</p>	
<b>General Purpose</b> GP	<p><b>Load</b> Machine power is mostly medium, but occasionally high. Bucket movements are smooth with minor shock load. Bucket penetrates easily.</p> <p><b>Wear</b> Material is lightly abrasive. Some sand may be medium abrasive.</p> <p><b>Soil</b> Mostly loose sand, gravel and finely broken materials.</p>	
<b>Heavy Duty</b> HD	<p><b>Load</b> Machine power is high during majority of the work. Medium, but continuous shock load.</p> <p><b>Wear</b> Material is abrasive. Light scratch marks can be seen at the bucket.</p> <p><b>Soil</b> Limestone, shot rock, compact mix of sand, gravel and clay.</p>	
<b>Extra Heavy Duty</b> XHD	<p><b>Load</b> Machine power is high during most of the work, often at maximum. Dynamic shock loads are frequent and machine may shake.</p> <p><b>Wear</b> Material is very abrasive. Large scratch marks are visible and, or deform metal. Works within heaps of rock with occasional un-shot rock and rock boulders.</p> <p><b>Soil</b> Granite, basalt, quartz sand, compact and sticky clay.</p>	

### Bucket Line-up

Category	Bucket Type	Capacity (m³)	Width*1 (mm)	Weight*2 (kg)	Tooth Quantity	Boom + Arm (m)			Tooth Type				
						5.7+1.8	5.7+2.4	5.7+2.9	Vertical	Horizontal	PAB*3	KMAX	KMAX II
LD	Conventional	1.17	1450	940	6	●	●	×	✓	✓			
GP	Conventional	0.50	750	478	3	○	○	○	✓	✓			
		0.80	1045	635	5	○	○	○	✓	✓			
		0.93	1200	696	5	□	□	●	✓	✓			
		1.00	1085	912	5	●	●	■		✓			
		1.05	1330	757	6	□	□	×	✓	✓			
		1.20	1200	939	5	■	■	■		✓			
HD	Conventional	0.80	1045	718	5	○	○	□		✓			
	Me Bucket	0.80	1045	765	5	○	○	□		✓	✓		✓
		0.93	1200	769	5	□	□	●		✓	✓		✓
XHD	Me Bucket	1.05	1330	1045	6	●	●	×		✓	✓		✓

\*1 Without side cutters \*2 With side cutters \*3 PAB: Pin And Bushing system ○: General purpose use, density up to 1.8 t/m³ □: General purpose use, density up to 1.5 t/m³  
 ●: Light duty work, density up to 1.2 t/m³ ■: Light duty work, density up to 0.9 t/m³ ×: Not usable ✓: Selectable

**Feature of [Me Bucket] (More suitable shape and Effectiveness Bucket)**

**High Productivity by Low-resistant Excavation**

The new Ideal bucket profile produces lower resistance at inside & outside bucket and production will be greatly increased.

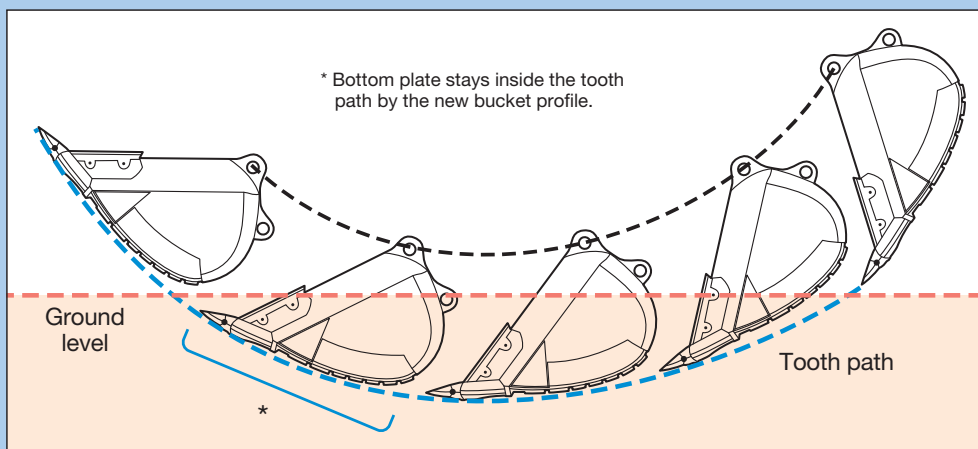

**Feature of [PAB Tooth] (Pin And Bushing system Tooth)**

- Able to fit on the bucket with horizontal pin type adapter
- Easy change-out only with a ratchet wrench
- Longer tooth life by easy rotation and turnover
- Durable and reusable PAB pin with flat surface

Limited to where horizontal pin type tooth is mainly used.

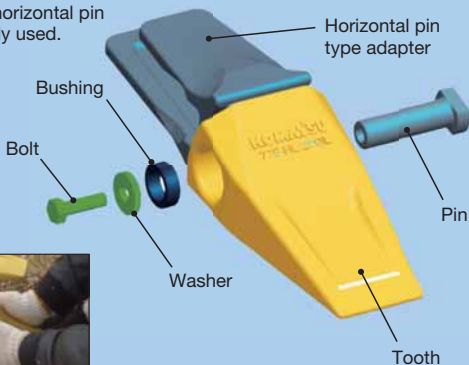

Set PAB tooth to horizontal pin type adapter



Insert exclusive pin to the adapter pin hole



Set bushing, washer and bolt and tighten by a ratchet wrench

**■ PAB Tooth Line-up**

Type	Style
Integrated Long Life IL	
Heavy Standard HS	
Heavy Rock HR	

**Feature of [KMAX II] Tooth**

**Fastener**

Simple, reusable fastener system saves time and money by unlocking with a simple 90-degree turn.

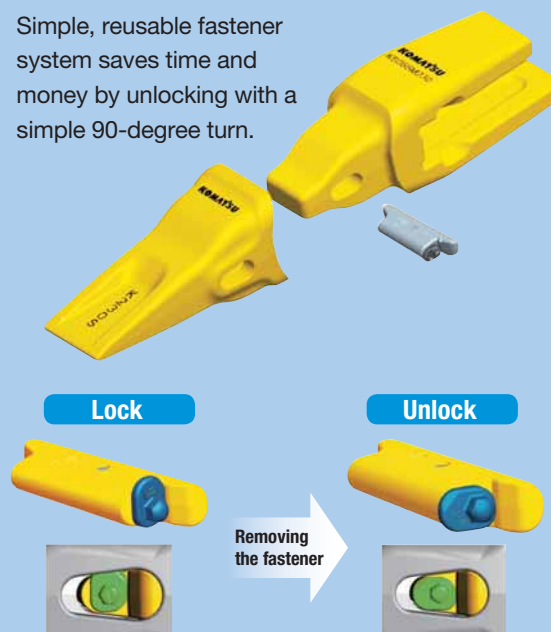

When removing the fastener, use the correct size socket to rotate the pin-locking shaft 90-degree counter-clockwise.

**■ KMAX II Tooth Line-up**

Type	Style
Standard S	
Long Life SL	
Heavy Standard HS	

## Special Purpose Bucket & Ripper

### ■ Feature and Specifications

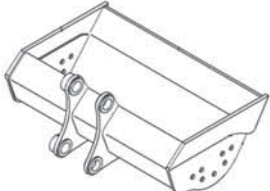
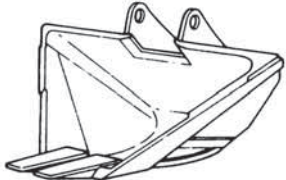
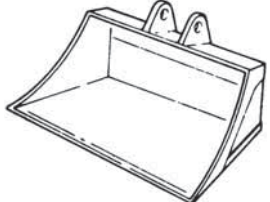
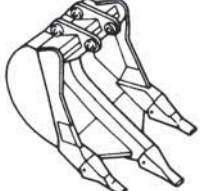
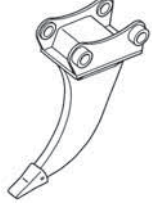
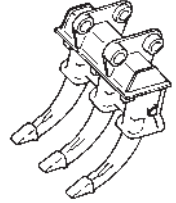
Type	Feature	Bucket Capacity (SAE J 296 Heaped)	Width	Image
<b>Ditch Cleaning Bucket</b>	Most suitable for cleaning a river or dredging soft soil from the river bed. The bucket has small holes which allow the water to drain, retaining only solid objects of the ditch.	0.80 m <sup>3</sup>	1800 mm	
<b>Trapezoidal Bucket</b>	Performs digging and sloping simultaneously on a drainage or irrigation canal. Using this bucket will leave the digging profile shaped as a cross-section.	0.70 m <sup>3</sup>	—	
<b>Slope Finishing Bucket</b>	The wide bucket width and flat bottom make this bucket suitable for smoothing the slopes of irrigation canals, roads or river banks.	0.40 m <sup>3</sup>	2000 mm	
<b>Ripper Bucket</b>	Suitable for digging rock bed or hard clayey soil when normal buckets cannot penetrate deep enough. Loading is also possible.	0.62 m <sup>3</sup>	990 mm	
<b>Single-shank Ripper</b>	This ripper is used for site preparation prior to digging work, when it becomes necessary to remove rocks, pavement for other obstacles. Also effective for pulling out tree stumps.	—	—	
<b>Three-shank Ripper</b>	This ripper is an efficient tool for digging up rocks on a slope, digging, crushing and ripping of concrete surfaces, and pulling out tree stumps.	—	—	

# HENSLEY BRAND BUCKET

## Diverse Bucket Capacity by Application Featuring "KMAX" Tooth System



- Wide range selection for each application
- Larger profile and capacity to maximize production
- Multiple width options to meet specific job requirements and reduce backfill

### Category and Recommended Applications

Category	Recommended Applications	Image
<b>Trenching and Loading TL</b>	Dirt, loam, sand, gravel, loose clay, abrasive soils with limited rock mixture.	
<b>Heavy Duty Plate Lip Bucket with Wear Plate HP</b>	Abrasive soils, compact or dense clay, loose rock and gravel.	
<b>Heavy Duty Plate Lip Bucket with Wear Plate &amp; Wear Strips HPS</b>	Abrasive soils, compact or dense clay, loose rock and gravel.	
<b>Extreme Duty Plate Lip Bucket with Special Features HPX</b>	Shot rock, stratified materials, quarry or tough, highly abrasive applications.	

### Bucket Line-up

Category	Capacity (m³)	Width (mm)	Weight (kg)	Tooth Quantity	Boom + Arm (m)			Tooth Type
					5.7+1.8	5.7+2.4	5.7+2.9	
TL	0.67	762	689	4	○	○	○	✓
	0.85	914	780	5	○	○	○	✓
	1.03	1067	857	5	○	□	□	✓
	1.20	1219	949	6	□	●	●	✓
	1.38	1372	1026	6	●	●	■	✓
HP	0.50	610	652	3	○	○	○	✓
	0.67	762	763	4	○	○	○	✓
	0.85	914	868	5	○	○	○	✓
	1.03	1067	950	5	○	□	●	✓
	1.20	1219	1066	6	□	●	■	✓
HPS	0.50	610	724	3	○	○	○	✓
	0.67	762	840	4	○	○	○	✓
	0.85	914	962	5	○	○	●	✓
	1.03	1067	1061	5	○	□	●	✓
	1.20	1219	1193	6	●	●	■	✓
HPX	0.50	610	824	3	○	○	○	✓
	0.67	762	939	4	○	○	○	✓
	0.85	914	1061	5	○	○	□	✓
	1.03	1067	1161	5	□	●	●	✓
	1.20	1219	1293	6	●	■	■	✓
1.38	1372	1383	6	■	■	×	✓	

○: General purpose use, density up to 1.8 t/m³ □: General purpose use, density up to 1.5 t/m³  
 ●: Light duty work, density up to 1.2 t/m³ ■: Light duty work, density: up to 0.9 t/m³  
 ×: Not usable ✓: Selectable

### Feature of KMAX Tooth System

- Better penetration and cycle times
- Hardness throughout the tooth
- Unique high strength design
- Unique reusable fastener
- Less "throw away" waste
- Fast tooth changeover



#### Tooth

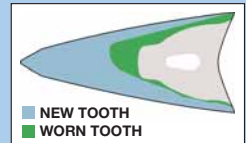

The KMAX RC style tooth shown here offers a consumption ratio of 60%.

#### Fastener

Simple, reusable fastener system saves time and money by unlocking with a simple 90-degree turn.



To lock, use the correct size socket, rotate the pin locking shaft 90-degree clockwise to finish the installation.



When removing the fastener, use the correct size socket to rotate the pin-locking shaft 90-degree counter-clockwise.

### KMAX Tooth Line-up

Feature	Style
<b>F Flare:</b> Loose material for clean bottom and greater fill	
<b>SYL Standard:</b> General applications	
<b>SD Chisel:</b> General purpose tooth Designed for penetration	
<b>RC Rock Chisel:</b> Designed for penetration and long wear life	
<b>T Tiger:</b> Designed for good penetration with ribs for strength	
<b>TV Tiger:</b> Offers best penetration in tight material	
<b>UT Twin Tiger:</b> Offers longer life penetration for corners	
<b>WT Twin Tiger:</b> Designed for penetration for corners	

Some application may not have been available in your country or region. If you are interested in such application, please contact a KOMATSU office near you.

# SPECIAL SPECS.

## Attachment Piping Specification

Equips PC200-8M0 for breaker and crusher installation. Hydraulic flow rate can be regulated by setting Breaker Mode on monitor panel during breaker operation.



Accumulator



Pilot filter



Additional filter for breaker



Heavy duty arm

Stop valve



Operating pedal



## Super Long Front

Super long front attachment boasts a huge digging reach. An excavator with this attachment highly improves working efficiency in various works such as river conservation, lake dredging, slopefinishing and materials carrying where an extensively long reach is required.

### Specifications

	PC200-8M0	PC200LC-8M0	
Reach	15 m	15 m	18 m
Max. Bucket Capacity (SAE J 296 Heaped)	0.37 m <sup>3</sup>	0.45 m <sup>3</sup>	0.29 m <sup>3</sup>
Boom Length	8.6 m	8.6 m	10.3 m
Arm Length	6.4 m	6.4 m	8.2 m



# ATTACHMENT

## Komatsu Genuine Attachment Tool

Komatsu-recommended attachment tools for hydraulic excavators  
A wide range of attachment tools are provided to suit customers' specific applications.

### Hydraulic breaker

The hydraulic breaker is an attachment tool used for crushing rock beds and paved surfaces, demolishing concrete structures, etc. The large gas chamber, ideal gas pressure ratio, and long-stroke piston deliver a powerful impact force. Since the breaker unit does not require an accumulator, the number of parts has been reduced, resulting in lower maintenance costs.



### Crusher

This attachment tool is used for demolishing concrete structures. Since it does not have a striking mechanism and features low noise and low vibration, it is suitable for work in urban areas. The open-close cylinder is equipped with a speed-up valve for increasing work speed.



Primary crusher

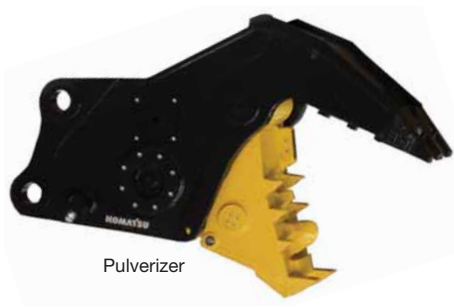

Pulverizer

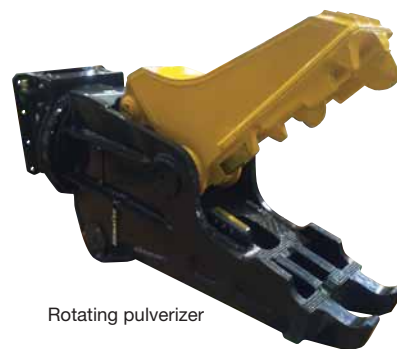

Rotating pulverizer



## Applications of Attachment Tools

Application/ Attachment Tool	Civil Engineering	Quarry	Demolition	Industrial Waste Disposal	Iron-Making	Utility Construction	Rental
Hydraulic Breaker	○	○	○	○	○	○	○
Crusher (Primary Crusher)			○				○
Crusher (Pulverizer)			○	○			○

# KOMATSU TOTAL SUPPORT



## Komatsu Total Support

To keep your machine available and minimize operation cost when you need it, Komatsu Distributor is ready to provide variety of support before and after procuring the machine.

### Fleet recommendation

Komatsu Distributor can study customer job site and provide the most optimum fleet recommendation with detailed information to meet all of your application needs when you are considering to buy new machines or to replace the existing ones from Komatsu.



### Product support

Komatsu Distributor secure the certain quality of machine will be delivered.

### Parts availability

Komatsu Distributor is available for emergency inquiry by the customers for genuine, quality guaranteed Komatsu parts.

### Technical support

Komatsu product support service (Technical support) are designed to help customer. Komatsu Distributor offers a variety of effective services how much Komatsu is dedicated to the maintenance and support of Komatsu machine.

- Preventive Maintenance (PM) clinic
- Oil & Wear analysis program
- Undercarriage inspection service, etc.

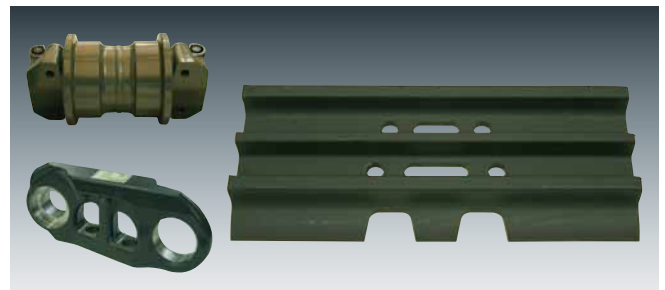

### Repair & maintenance service

Komatsu Distributor offers quality repair service, periodical maintenance, and maintenance service to the customer, utilizing and promoting Komatsu developed programs.

### Komatsu Reman (Remanufactured) components

Komatsu Reman products are the result of the implementation of the Komatsu global Reman policy which establishes and agrees to reduce the owning, operating and total Life Cycle Costs (LCC) to Komatsu's customer through prompt delivery, high quality and competitively priced in own remanufactured products (QDC).



# SPECIFICATIONS



## ENGINE

Model ..... Komatsu SAA6D107E-1  
 Type ..... Water-cooled, 4-cycle, direct injection  
 Aspiration ..... Turbocharged, aftercooled  
 Number of cylinders ..... 6  
 Bore ..... 107 mm  
 Stroke ..... 124 mm  
 Piston displacement ..... 6.69 L  
 Horsepower:  
   SAE J1995 ..... Gross 110 kW 147 HP  
   ISO 9249 / SAE J1349 ..... Net 103 kW 138 HP  
   Rated rpm ..... 2000 min<sup>-1</sup>  
 Fan drive method for radiator cooling ..... Mechanical  
 Governor ..... All-speed control, electronic

U.S. EPA Tier 3 and EU Stage 3A emissions equivalent.



## HYDRAULICS

Type .. HydraulMind (Hydraulic Mechanical Intelligence New Design) system, closed-center system with load sensing valves and pressure compensated valves  
 Number of selectable working modes ..... 6  
 Main pump:  
   Type ..... Variable displacement piston type  
   Pumps for ..... Boom, arm, bucket, swing, and travel circuits  
   Maximum flow ..... 439 L/min  
   Supply for control circuit ..... Self-reducing valve  
 Hydraulic motors:  
   Travel ..... 2 x axial piston motor with parking brake  
   Swing ..... 1 x axial piston motor with swing holding brake  
 Relief valve setting:  
   Implement circuits ..... 37.3 MPa 380 kg/cm<sup>2</sup>  
   Travel circuit ..... 37.3 MPa 380 kg/cm<sup>2</sup>  
   Swing circuit ..... 28.9 MPa 295 kg/cm<sup>2</sup>  
   Pilot circuit ..... 3.2 MPa 33 kg/cm<sup>2</sup>  
 Hydraulic cylinders:  
 (Number of cylinders – bore x stroke x rod diameter)  
   Boom ..... 2–120 mm x 1334 mm x 85 mm  
   Arm ..... 1–135 mm x 1490 mm x 95 mm  
   Bucket for 2.93 m arm ..... 1–115 mm x 1120 mm x 80 mm  
   for 2.41 m arm ..... 1–115 mm x 1120 mm x 80 mm  
   for 1.84 m arm ..... 1–125 mm x 1110 mm x 85 mm



## DRIVES AND BRAKES

Steering control ..... Two levers with pedals  
 Drive method ..... Hydrostatic  
 Maximum drawbar pull ..... 178 kN 18200 kg  
 Gradeability ..... 70%, 35°  
 Maximum travel speed: High ..... 5.5 km/h  
 (Auto-shift) Mid ..... 4.1 km/h  
 (Auto-shift) Low ..... 3.0 km/h  
 Service brake ..... Hydraulic lock  
 Parking brake ..... Mechanical disc brake



## SWING SYSTEM

Drive method ..... Hydrostatic  
 Swing reduction ..... Planetary gear  
 Swing circle lubrication ..... Grease-bathed  
 Service brake ..... Hydraulic lock  
 Holding brake/Swing lock ..... Mechanical disc brake  
 Swing speed ..... 12.4 min<sup>-1</sup>



## UNDERCARRIAGE

Center frame ..... X-frame  
 Track frame ..... Box-section  
 Seal of track ..... Sealed track  
 Track adjuster ..... Hydraulic  
 Number of shoes (Each side):  
   PC200-8M0 ..... 45  
   PC200LC-8M0 ..... 49  
 Number of carrier rollers ..... 2 each side  
 Number of track rollers (Each side):  
   PC200-8M0 ..... 7  
   PC200LC-8M0 ..... 9



## COOLANT AND LUBRICANT CAPACITY (REFILLING)

Fuel tank ..... 400 L  
 Coolant ..... 20.4 L  
 Engine ..... 23.1 L  
 Final drive (Each side) ..... 3.6 L  
 Swing drive ..... 6.5 L  
 Hydraulic tank ..... 135 L



## OPERATING WEIGHT (APPROXIMATE)

Operating weight including 5700 mm one-piece boom, 2925 mm arm, SAE J 296 heaped 0.80 m<sup>3</sup> backhoe bucket, rated capacity of lubricants, coolant, full fuel tank, operator, and standard equipment.

Shoes	PC200-8M0		PC200LC-8M0	
	Operating Weight	Ground Pressure	Operating Weight	Ground Pressure
500 mm	19800 kg	54.9 kPa 0.56 kg/cm <sup>2</sup>	—	—
600 mm	19900 kg	46.1 kPa 0.47 kg/cm <sup>2</sup>	20700 kg	43.1 kPa 0.44 kg/cm <sup>2</sup>
700 mm	20200 kg	40.2 kPa 0.41 kg/cm <sup>2</sup>	21100 kg	37.2 kPa 0.38 kg/cm <sup>2</sup>
800 mm	20500 kg	35.3 kPa 0.36 kg/cm <sup>2</sup>	21400 kg	33.3 kPa 0.34 kg/cm <sup>2</sup>
900 mm	—	—	21700 kg	30.4 kPa 0.31 kg/cm <sup>2</sup>



## DIMENSIONS

Arm Length	1840 mm	2410 mm	2925 mm
<b>A</b> Overall length	9480 mm	9495 mm	9425 mm
<b>B</b> Length on ground (Transport): PC200-8M0 PC200LC-8M0	6270 mm	5700 mm	4815 mm
	6455 mm	5885 mm	5000 mm
<b>C</b> Overall height (To top of boom)	2985 mm	3190 mm	2970 mm

	PC200-8M0	PC200LC-8M0
<b>D</b> Overall width	2800 mm	3080 mm
<b>E</b> Overall height (To top of cab)	3040 mm	3040 mm
<b>F</b> Ground clearance, counterweight	1085 mm	1085 mm
<b>G</b> Ground clearance (Minimum)	440 mm	440 mm
<b>H</b> Tail swing radius	2750 mm	2750 mm
<b>I</b> Track length on ground	3275 mm	3655 mm
<b>J</b> Track length	4070 mm	4450 mm
<b>K</b> Track gauge	2200 mm	2380 mm
<b>L</b> Width of crawler	2800 mm	3080 mm
<b>M</b> Shoe width	600 mm	700 mm
<b>N</b> Grouser height	26 mm	26 mm
<b>O</b> Machine cab height	2095 mm	2095 mm
<b>P</b> Machine cab width	2710 mm	2710 mm
<b>Q</b> Distance, swing center to rear end	2710 mm	2710 mm

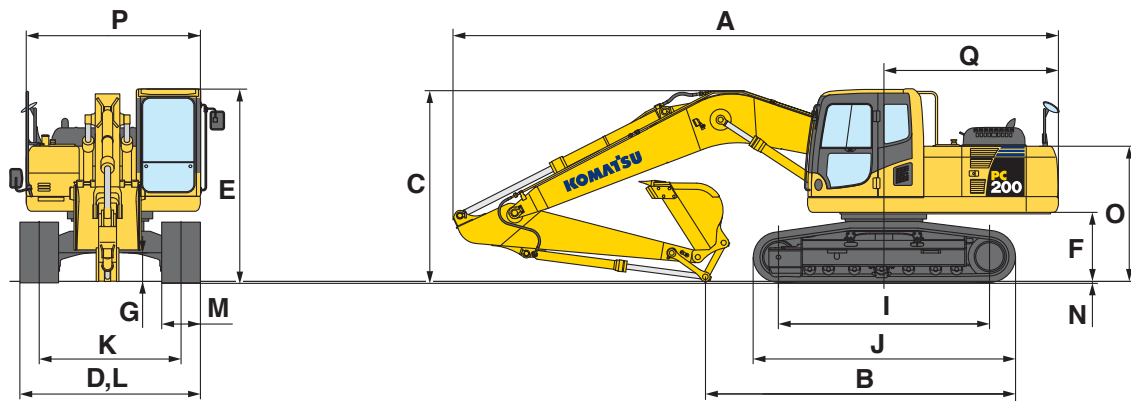
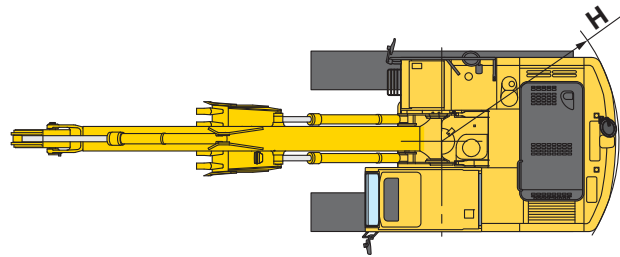

 **WORKING RANGE**

Arm Length		1840 mm	2410 mm	2925 mm
<b>A</b>	Max. digging height	9500 mm	9800 mm	10000 mm
<b>B</b>	Max. dumping height	6630 mm	6890 mm	7110 mm
<b>C</b>	Max. digging depth	5380 mm	6095 mm	6620 mm
<b>D</b>	Max. vertical wall digging depth	4630 mm	5430 mm	5980 mm
<b>E</b>	Max. digging depth of cut for 2440 mm level	5130 mm	5780 mm	6370 mm
<b>F</b>	Max. digging reach	8850 mm	9380 mm	9875 mm
<b>G</b>	Max. digging reach at ground level	8660 mm	9190 mm	9700 mm
<b>H</b>	Min. swing radius	3010 mm	3090 mm	3040 mm
<b>SAE J 1179 Rating</b>	Bucket digging force at power max.	157 kN 16000 kg	138 kN 14100 kg	138 kN 14100 kg
	Arm crowd force at power max.	139 kN 14200 kg	124 kN 12600 kg	101 kN 10300 kg
<b>ISO 6015 Rating</b>	Bucket digging force at power max.	177 kN 18000 kg	149 kN 15200 kg	149 kN 15200 kg
	Arm crowd force at power max.	145 kN 14800 kg	127 kN 13000 kg	108 kN 11000 kg

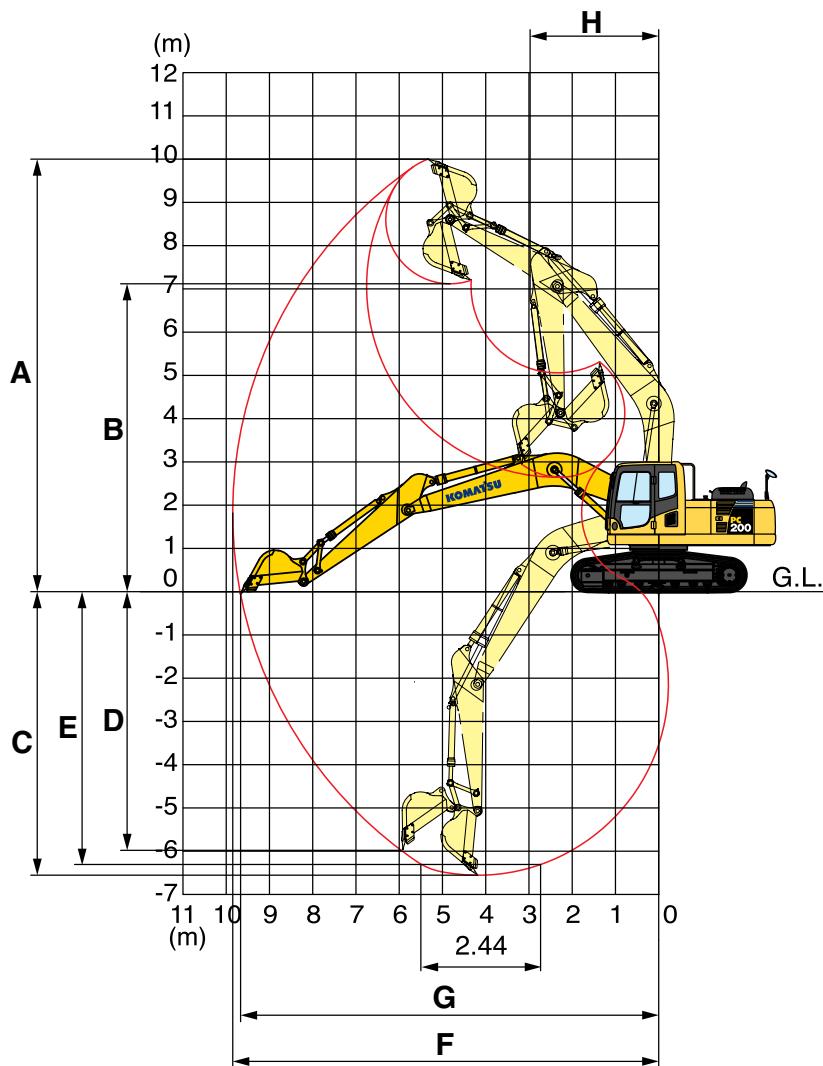



## LIFTING CAPACITY WITH LIFTING MODE

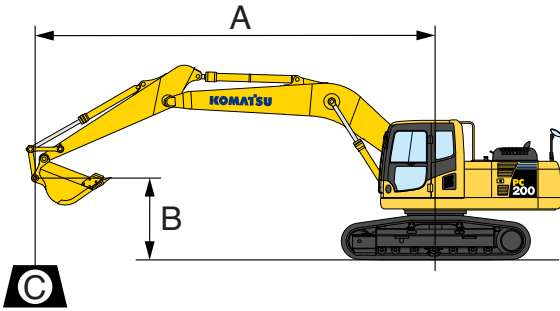

- A: Reach from swing center
- B: Bucket hook height
- C: Lifting capacity
- Cf: Rating over front
- Cs: Rating over side
- ⊗: Rating at maximum reach

### Conditions:

- 5700 mm one-piece boom
- 0.8 m<sup>3</sup> SAE J 296 heaped bucket
- Shoe width:
  - PC200-8M0 600 mm triple grouser

PC200-8M0		Arm: 1840 mm		Bucket: 0.8 m <sup>3</sup> SAE J 296 heaped				Shoe: 600 mm triple grouser					
B	A	⊗ MAX		7.5 m		6.0 m		4.5 m		3.0 m		1.5 m	
		Cf	Cs	Cf	Cs	Cf	Cs	Cf	Cs	Cf	Cs	Cf	Cs
7.5 m		*5100 kg	*5100 kg					*5600 kg	*5600 kg				
6.0 m		*4800 kg	3600 kg			*5550 kg	3950 kg	*5800 kg	*5800 kg				
4.5 m		4400 kg	2850 kg			5850 kg	3800 kg	*7350 kg	6150 kg	*10350 kg	*10350 kg		
3.0 m		3900 kg	2500 kg	3850 kg	2450 kg	5600 kg	3600 kg	9000 kg	5650 kg				
1.5 m		3750 kg	2350 kg	3750 kg	2350 kg	5400 kg	3400 kg	8550 kg	5200 kg				
0 m		3900 kg	2400 kg	3700 kg	2300 kg	5250 kg	3250 kg	8350 kg	5050 kg				
-1.5 m		4400 kg	2750 kg			5200 kg	3250 kg	8350 kg	5050 kg	*9500 kg	*9500 kg		
-3.0 m		5750 kg	3600 kg			5350 kg	3350 kg	8500 kg	5200 kg	*13000 kg	10300 kg		

PC200-8M0		Arm: 2410 mm		Bucket: 0.8 m <sup>3</sup> SAE J 296 heaped				Shoe: 600 mm triple grouser					
B	A	⊗ MAX		7.5 m		6.0 m		4.5 m		3.0 m		1.5 m	
		Cf	Cs	Cf	Cs	Cf	Cs	Cf	Cs	Cf	Cs	Cf	Cs
7.5 m		*4500 kg	4250 kg										
6.0 m		*4250 kg	3000 kg			*4850 kg	4050 kg						
4.5 m		3800 kg	2450 kg	4000 kg	2600 kg	*5450 kg	3900 kg	*6400 kg	6300 kg				
3.0 m		3450 kg	2150 kg	3900 kg	2500 kg	5650 kg	3650 kg	*8650 kg	5800 kg				
1.5 m		3300 kg	2050 kg	3750 kg	2350 kg	5450 kg	3450 kg	8650 kg	5300 kg				
0 m		3400 kg	2100 kg	3700 kg	2300 kg	5250 kg	3250 kg	8350 kg	5050 kg	*7000 kg	*7000 kg		
-1.5 m		3750 kg	2350 kg	3650 kg	2250 kg	5200 kg	3200 kg	8300 kg	5000 kg	*9300 kg	*9300 kg	*7700 kg	*7700 kg
-3.0 m		4650 kg	2900 kg			5250 kg	3250 kg	8400 kg	5100 kg	*14600 kg	10200 kg		
-4.5 m		*7150 kg	4500 kg					*8300 kg	5350 kg	*11650 kg	10400 kg		

PC200-8M0		Arm: 2925 mm		Bucket: 0.8 m <sup>3</sup> SAE J 296 heaped				Shoe: 600 mm triple grouser					
B	A	⊗ MAX		7.5 m		6.0 m		4.5 m		3.0 m		1.5 m	
		Cf	Cs	Cf	Cs	Cf	Cs	Cf	Cs	Cf	Cs	Cf	Cs
7.5 m		*2900 kg	*2900 kg			*4050 kg	*4050 kg						
6.0 m		*2750 kg	2600 kg	*3100 kg	2600 kg	*4250 kg	4100 kg						
4.5 m		*2750 kg	2150 kg	4000 kg	2550 kg	*4850 kg	3900 kg	*5500 kg	*5500 kg				
3.0 m		*2900 kg	1900 kg	3850 kg	2450 kg	5650 kg	3650 kg	*7700 kg	5850 kg	*11600 kg	11450 kg		
1.5 m		2950 kg	1800 kg	3700 kg	2300 kg	5400 kg	3400 kg	8700 kg	5300 kg	*6800 kg	*6800 kg		
0 m		3000 kg	1800 kg	3600 kg	2200 kg	5150 kg	3200 kg	8300 kg	4950 kg	*5150 kg	*5150 kg		
-1.5 m		3300 kg	2000 kg	3550 kg	2150 kg	5050 kg	3050 kg	8100 kg	4850 kg	*9300 kg	*9300 kg	*5150 kg	*5150 kg
-3.0 m		3950 kg	2400 kg			5050 kg	3100 kg	8200 kg	4900 kg	*14800 kg	9850 kg	*9700 kg	*9700 kg
-4.5 m		5700 kg	3500 kg					8400 kg	5100 kg	*12950 kg	10200 kg		

\* Load is limited by hydraulic capacity rather than tipping. Ratings are based on SAE J1097. Rated loads do not exceed 87% of hydraulic lift capacity or 75% of tipping load.



**LIFTING CAPACITY WITH LIFTING MODE**

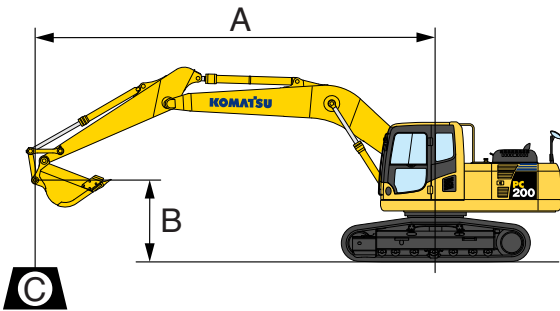

- A: Reach from swing center
- B: Bucket hook height
- C: Lifting capacity
- Cf: Rating over front
- Cs: Rating over side
- ⊗: Rating at maximum reach

- Conditions:
- 5700 mm one-piece boom
  - 0.8 m<sup>3</sup> SAE J 296 heaped bucket
  - Shoe width:
    - PC200LC-8M0 700 mm triple grouser

PC200LC-8M0		Arm: 1840 mm		Bucket: 0.8 m <sup>3</sup> SAE J 296 heaped				Shoe: 700 mm triple grouser					
B	A	⊗ MAX		7.5 m		6.0 m		4.5 m		3.0 m		1.5 m	
		Cf	Cs	Cf	Cs	Cf	Cs	Cf	Cs	Cf	Cs	Cf	Cs
7.5 m		*5100 kg	*5100 kg					*5600 kg	*5600 kg				
6.0 m		*4800 kg	4150 kg			*5550 kg	4550 kg	*5800 kg	*5800 kg				
4.5 m		*4900 kg	3300 kg	4750 kg	2900 kg	*6000 kg	4400 kg	*7350 kg	7050 kg	*10350 kg	*10350 kg		
3.0 m		4850 kg	2900 kg	4650 kg	2800 kg	6900 kg	4200 kg	*9700 kg	6550 kg				
1.5 m		4650 kg	2800 kg	4600 kg	2750 kg	6700 kg	4000 kg	*10700 kg	6100 kg				
0 m		4850 kg	2850 kg			6550 kg	3850 kg	10600 kg	5950 kg				
-1.5 m		5450 kg	3250 kg			6500 kg	3800 kg	*10600 kg	5950 kg	*9500 kg	*9500 kg		
-3.0 m		7150 kg	4200 kg			6650 kg	3950 kg	*9750 kg	6100 kg	*13000 kg	12250 kg		

PC200LC-8M0		Arm: 2410 mm		Bucket: 0.8 m <sup>3</sup> SAE J 296 heaped				Shoe: 700 mm triple grouser					
B	A	⊗ MAX		7.5 m		6.0 m		4.5 m		3.0 m		1.5 m	
		Cf	Cs	Cf	Cs	Cf	Cs	Cf	Cs	Cf	Cs	Cf	Cs
7.5 m		*4500 kg	*4500 kg										
6.0 m		*4250 kg	3500 kg			*4850 kg	4650 kg						
4.5 m		*4300 kg	2850 kg	4900 kg	3000 kg	*5450 kg	4500 kg	*6400 kg	*6400 kg				
3.0 m		4250 kg	2550 kg	4800 kg	2900 kg	*6400 kg	4200 kg	*8650 kg	6750 kg				
1.5 m		4100 kg	2450 kg	4700 kg	2800 kg	6750 kg	4000 kg	*10550 kg	6250 kg				
0 m		4250 kg	2500 kg	4600 kg	2700 kg	6550 kg	3850 kg	10650 kg	5950 kg	*7000 kg	*7000 kg		
-1.5 m		4700 kg	2750 kg	4550 kg	2700 kg	6500 kg	3800 kg	10550 kg	5900 kg	*9300 kg	*9300 kg	*7700 kg	*7700 kg
-3.0 m		5800 kg	3400 kg			6550 kg	3850 kg	*10350 kg	6000 kg	*14600 kg	12200 kg		
-4.5 m		*7150 kg	5250 kg					*8300 kg	6250 kg	*11650 kg	*11650 kg		

PC200LC-8M0		Arm: 2925 mm		Bucket: 0.8 m <sup>3</sup> SAE J 296 heaped				Shoe: 700 mm triple grouser					
B	A	⊗ MAX		7.5 m		6.0 m		4.5 m		3.0 m		1.5 m	
		Cf	Cs	Cf	Cs	Cf	Cs	Cf	Cs	Cf	Cs	Cf	Cs
7.5 m		*2900 kg	*2900 kg			*4050 kg	*4050 kg						
6.0 m		*2750 kg	*2750 kg	*3100 kg	3050 kg	*4250 kg	*4250 kg						
4.5 m		*2750 kg	2550 kg	*4600 kg	3000 kg	*4850 kg	4500 kg	*5500 kg	*5500 kg				
3.0 m		*2900 kg	2250 kg	4800 kg	2850 kg	*5900 kg	4200 kg	*7700 kg	6800 kg	*11600 kg	*11600 kg		
1.5 m		*3200 kg	2150 kg	4600 kg	2750 kg	6700 kg	3950 kg	*9800 kg	6250 kg	*6800 kg	*6800 kg		
0 m		*3700 kg	2200 kg	4500 kg	2600 kg	6500 kg	3750 kg	10550 kg	5850 kg	*5150 kg	*5150 kg		
-1.5 m		4150 kg	2400 kg	4450 kg	2550 kg	6350 kg	3650 kg	10400 kg	5750 kg	*9300 kg	*9300 kg	*5150 kg	*5150 kg
-3.0 m		4950 kg	2900 kg			6350 kg	3650 kg	*10400 kg	5800 kg	*14800 kg	11800 kg	*9700 kg	*9700 kg
-4.5 m		*6700 kg	4100 kg					*9100 kg	6000 kg	*12950 kg	*12000 kg		

\* Load is limited by hydraulic capacity rather than tipping. Ratings are based on SAE J1097. Rated loads do not exceed 87% of hydraulic lift capacity or 75% of tipping load.



## STANDARD EQUIPMENT

### ENGINE:

- Automatic engine warm-up system
- Dry type air cleaner, double element
- Engine, Komatsu SAA6D107E-1
- Engine overheat prevention system
- Radiator and oil cooler dust proof net
- Suction fan

### ELECTRICAL SYSTEM:

- Alternator, 24 V/35 A
- Auto-decelerator
- Batteries, 2 X 12 V/110 Ah
- Starting motor, 24 V/4.5 kW
- Working light, 2 (boom and RH)

### HYDRAULIC SYSTEM:

- Boom holding valve
- Power maximizing system
- Pressure Proportional Control (PPC) hydraulic control system
- Working mode selection system

### GUARDS AND COVERS:

- Fan guard structure
- Track guiding guard, center section

### UNDERCARRIAGE:

- Hydraulic track adjusters (Each side)
- Track roller
  - PC200-8M0, 7 each side
  - PC200LC-8M0, 9 each side
- Track shoe
  - PC200-8M0, 600 mm triple grouser
  - PC200LC-8M0, 700 mm triple grouser

### OPERATOR ENVIRONMENT:

- Equipment management monitoring system
- Large multi-lingual high resolution LCD monitor
- Rear view mirrors (RH, LH, rear, sidewise)
- ROPS cab (ISO 12117-2)

### OTHER EQUIPMENT:

- Counterweight
- Electric horn
- Rear reflector
- Slip-resistant plates
- Travel alarm



## OPTIONAL EQUIPMENT

### ENGINE:

- Additional filter system for poor-quality fuel (Water separator)
- Air pre-cleaner
- Large capacity fuel pre-filter

### ELECTRICAL SYSTEM:

- Alternator, 24 V/60 A
- Batteries, large capacity
- Working lights
  - 2 on cab
  - 1 on counterweight

### HYDRAULIC SYSTEM:

- Long lubricating intervals for work equipment bushing (500 hours)
- Service valve

### UNDERCARRIAGE:

- Shoes, triple grouser shoes
  - PC200-8M0 500 mm, 700 mm, 800 mm
  - PC200LC-8M0 600 mm, 800 mm, 900 mm
- Track frame undercover
- Track roller guards (Full length)

### OPERATOR ENVIRONMENT:

- A/C with defroster
- Bolt-on top guard, OPG top guard level 2 (ISO 10262)
- Cab accessories
  - Rain visor
  - Sun visor
- Cab front guard
  - Full height guard
  - Half height guard

- Heater with defroster
- Rear view monitor system
- Seat belt, retractable
- Seat, suspension

### WORK EQUIPMENT:

- Arms
  - 1840 mm arm assembly
  - 2410 mm arm assembly
  - 2925 mm arm assembly
- Boom, 5700 mm

**KOMATSU**<sup>®</sup>