

GTJZ06M-6m ELECTRIC SCISSOR LIFT

Model	GTJZ06M
Working Height Maximum	7.8m
Platform Height Maximum	5.8m
Max platform occupancy	2
Lift capacity	230kg
Lift capacity-extension deck	120kg
Length(stowed) ①	1.86m
Width(stowed) ②	1m
Height(stowed)③	2.2m
Height(guardrail fold stowed)	1.8m
Platform height minimum ④	1.08m
Platform measurement ②*①	1.7*0.76m
Length extension deck	0.9m
Ground clearance-center	85/20mm
Turning radius Minimum	1.7m
Travel speed(stowed)	3.2km/h
Travel speed(raised)	0.8km/h
Grade-ability	25%
Max. allowable slope	1.5° / 3°
Tire	Φ 305*114 mm
Weight	1445kg
Lift motor	24/3 v/kw
battery	4*6/216V/Ah
Charger	24/30V/A

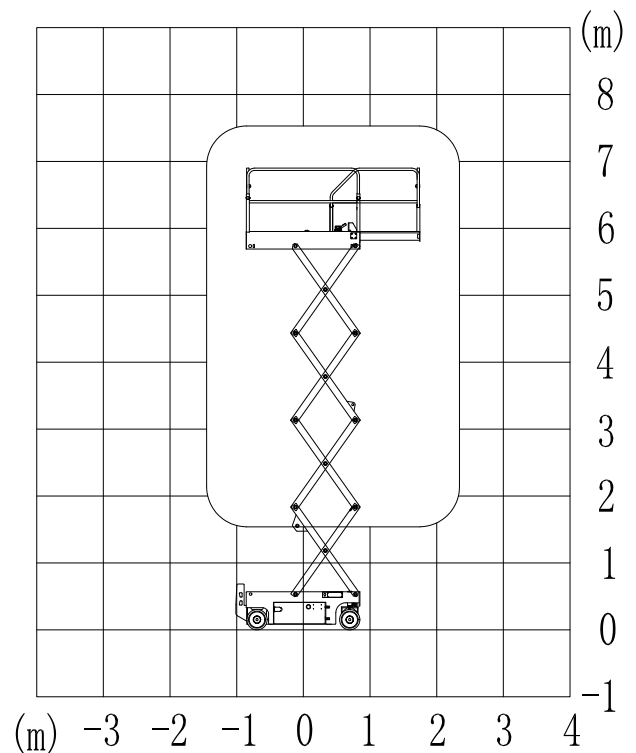
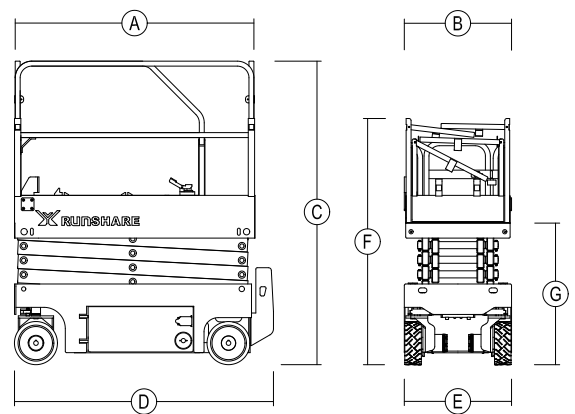

CONFIGURATION

DC motor --Bucher (USA)/ CB (China)
Hydraulic Pump--Bucher (USA)/Parker (China)
Valve--Hydrofoss (USA)
Brake--White (USA)/Dali (China)/Yiqun (China)
RE motor--White (USA) / Dali (China)
Brake release pump--White (USA) / Qiangtian (China)
Battery--US (USA) / Trojan (USA)
Charger--Longsheng (China)
Controller-DLT(USA)/ Ruitai /Zhongdian (China)
Hour meter--Curtis (USA)/ Honeywell (USA)

