



# SKID STEER LOADERS

RADIAL LIFT



2012 ▲ 2026 ▲ 2041 ▲ 2044 ▲ 2054 ▲ 2056 SERIES II ▲ 2076 ▲ 2086



# IN THE BEGINNING

**What began in the 19th century as an agricultural implement manufacturer has grown into a 21st century compact equipment powerhouse – Mustang Compact Equipment.**

Known in the early years as the Owatonna Manufacturing Company, Mustang was among the first to make what is known today as the skid steer loader. Since that time, Mustang has combined old-school experience with innovative processes to offer one of the broadest lines of compact equipment available today.

**MUSTANG. THE ORIGINAL WORKHORSE.**



# PUSHING the LIMITS



**Mustang is the second-oldest skid steer loader manufacturer in the world.** Building its first skid steer in 1965 – the Mustang Series 1000 – Mustang has pushed the limits of product innovation and set performance standards throughout the industry.

Over the years, the Mustang product line has become one of the most complete lines of compact equipment throughout the world.

Raw power – a hallmark Mustang feature – is provided by high-output, high-torque engines in every model. Superior ground-engaging capabilities and cycle-time performance are made possible by advanced, well-balanced hydraulic systems.

Hundreds of attachments are easily interchangeable to expand the uses of a Mustang skid steer loader.

Strength and durability are not afterthoughts; they are core characteristics carefully built into each skid steer loader at the Mustang manufacturing facility in Madison, South Dakota.



SKID STEER LOADERS

# COMPACT POWERHOUSE



## 2012



Don't let its size fool you. The 2012 skid steer from Mustang packs some serious punch into a super-compact package.

**COMPACT SIZE** ▲ This unit is made for maneuvering in tight areas where other machines can't gain access with a machine width as narrow as 914 mm with optional tires and 914 mm bucket, a height of 1897 mm and a length of 1905 mm.

**SOLID PERFORMANCE** ▲ With a 17.9 kW Yanmar diesel engine and a rated operating capacity of 386 kg, the 2012 provides performance in a small package.

**LIGHT-WEIGHT TRANSPORT** ▲ Machine shipping weight less than 1361 kg makes for easy loading and hauling.



**NARROW MACHINE WIDTH** ▲ of only 914 mm with 5.70 x 12 chevron tire set, and 1118 mm with 8.50 x 12 HD flotation tire set allows the 2012 to gain access where other machines can't go.



**ALL-DAY COMFORT** ▲ and protection in the operator-friendly ROPS/FOPS Level II-certified cab. A high-back, deluxe seat comes standard, a high-back suspension seat is optional.



**UNIQUE RESTRAINT BAR** ▲ design ties into the Hydraloc™ safety system, provides added protection and is fully adjustable for an ergonomic and safe operator's environment.

# EXPANDED OPTIONS



**LIFT ARM** ▲ features a high-strength, low-profile design maximizing operator visibility for added performance.



**MOVE MORE** ▲ with a lift height of 2438 mm which makes loading and material handling in small spaces easy.



**EASY MAINTENANCE** ▲ with the tiltable ROPS/FOPS and wide rear door provides access to service and maintenance points.

# STRONG

# COMPACT COLT



▶ 2026  
▶ 2041



Mustang skid steer loaders are known for their strength and durability. These little colts, the compact models 2026 and 2041, have a lot to live up to, but they don't disappoint.

**MANEUVERABLE** ▲ The low-profile design and width as narrow as 1229 mm on model 2026, and 1372 mm on model 2041 make working in small spaces easy.

**HIGH PERFORMANCE** ▲ Powerful, Stabe 3B-compliant Yanmar liquid-cooled diesel engines provide power when it is needed.

**STRONG** ▲ Increased operating loads up to 669 kg add strength to your fleet with the optional counterweight on model 2041.



**HIGH LIFT HEIGHTS** ▲ of up to 2794 mm make material handling in small, confined spaces easy.



**BE IN CONTROL** ▲ with T-bar hands-only or available hand/foot controls.



**MULTI-TASK** ▲ with a variety of attachments that can be powered by the auxiliary hydraulic system.

# DOUBLE DURABILITY



**FAST CYCLE TIMES** ▲ are achieved with the unique Mustang radial-lift arm design engineered for fast cycle times, strong breakout forces and high operating capacities.



**ADDED PROTECTION** ▲ with the sturdy Level II-certified ROPS/FOPS structure. Operators also enjoy an unobstructed, panoramic view to the attachment and surrounding work areas.



**UNIQUE RESTRAINT BAR** ▲ design is tied into the Hydraloc™ safety system, assuring operator safety by preventing engine start-up when the operator is not in the seat with the restraint bar in place.

MID-SIZED

# MUSCLE



▶ 2044  
▶ 2054



When maneuverability is key and high capacities are vital, contractors of all types – from concrete specialists to landscape professionals – turn to the Mustang mid-sized skid steers.

**RAW STRENGTH** ▲ Operating capacities of 658 kg on model 2044 and 748 kg on model 2054 (703 kg and 794 kg respectively with the optional counterweight).

**EXTRA BREAK OUT** ▲ Breakout forces up to 2268 kg provide extra muscle for tough jobs.

**POWERFUL** ▲ Both models feature an Interim Tier IV-compliant four-cylinder, 34.2 kW direct-injected Yanmar diesel engine.



**AUXILIARY HYDRAULIC** ▲ system powers a variety of attachments. Optional high-flow (*model 2054*) provides extra power when needed.



**HIGH LIFT HEIGHTS** ▲ of up to 2946 mm coupled with the compact machine design make material handling in small, confined spaces easy.



**GET QUIET** ▲ with the optional sound package that lowers noise levels, making a work day in the cab more comfortable for the operator.

# COMPACT & POWERFUL



**THREE CONTROL OPTIONS** ▲ are available to fit the needs of any operator. Control configurations include: dual lever with foot controls, dual lever with hand controls, and T-bar with foot controls.



**ADDED PROTECTION** ▲ is achieved with the sturdy Level I-certified ROPS/FOPS structure. Operators also enjoy an unobstructed, panoramic view to the attachment and surrounding work areas.



**FAST CYCLE TIMES** ▲ are achieved with the unique Mustang radial-lift arm design engineered for fast cycle times, strong breakout forces and high operating capacities.

FULL-  
SIZED

# STALLIONS



▶ 2056 SERIES II

▶ 2076

▶ 2086



These full-sized stallions are the perfect combination of raw power and maneuverability.

**HIGH HORSEPOWER** ▲ Advanced Yanmar 52.7 kW Interim Tier IV diesel engines keep the 2076 and 2086 powered up. The model 2056 Series II features a 50.7 kW Yanmar Interim Tier IV engine.

**COMPACT STATURE** ▲ Models 2076 and 2086 have a compact 1841 mm width, bringing power to smaller spaces. The model 2056 Series II is as narrow as 1516 mm with offset tire and wheel package, allowing it to fit easily on sidewalks.

**ADDED STRENGTH** ▲ Operating capacities up to 1315 kg with optional counterweight add strength to your compact skid steer fleet.



**EXCEPTIONAL HYDRAULIC PRESSURE** ▲ powers a wide variety of attachments. High breakout forces and engine torque provide added performance.



**ROOMY CABS** ▲ come standard with an adjustable suspension seat (optional on 2056 Series II), dome light, work lights, and choice of hand/foot, dual hand or joystick controls.



**HYDRAGLIDE™** ▲ ride control is a standard feature with certain control configurations that allows the bucket to "float" in carry position, reducing the amount of material spillage.

# RAW PERFORMANCE



**HIGH START-UP TORQUE** ▲ for rapid acceleration with or without a load is made possible by maintenance-free, radial-piston drive motors.



**OPTIONAL POWER-A-TACH®** ▲ hydraulic attachment system allows the operator to change buckets and attachments without leaving the seat.



**WIDE TREAD WIDTH** ▲ and low center-of-gravity on models 2076 and 2086 provide superior stability for optimal performance on rough, uneven surfaces.

2056 SERIES II ▲ 2076 ▲ 2086

# CLIMB INTO THE SADDLE



## EXCELLENT VISIBILITY ▲

A cab-forward design enhances the view to the bucket cutting edge from the operator's seat.



**SOUND REDUCTION ▲** Lower noise levels in the operator's compartment allows for increased operator comfort and productivity.

*Not available on model 2012*

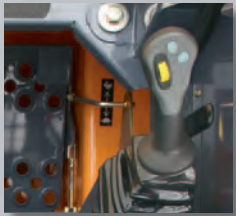

## JOYSTICK CONTROLS ▲

Fully adjustable joystick control towers and an air-ride suspension seat option provide extreme comfort.

*Available on models 2056 Series II, 2076 and 2086.*



## PRESSURIZED CAB ▲

An optional, pressurized, sealed cab enclosure provides a cleaner, quieter operating environment with heat, or heat and air-conditioning.



## INSTRUMENTATION ▲

All instrumentation is conveniently located in the upper-right and left-instrument panels for easy access.

The cab is the operational core for any job.

Mustang understands this and provides an operator's station with the options needed to customize it to YOUR needs.



# TIME IS MONEY GET ATTACHED

With a wide variety of MUSTANG® attachments available from your dealer, Mustang Skid Steer Loaders are easily transformed to meet the needs of your business.



**MUSTANG**



**MULTI-TACH® SYSTEM ▲**  
standard on all models, this universal-style attachment mounting system is compatible with most allied attachments.



**POWER-A-TACH® SYSTEM ▲**  
optional on many models, this system allows users to quickly install and remove attachments, leaving the seat only to connect auxiliary hydraulics.

GET ATTACHED

# SKID STEER SPECIFICATIONS

		2012	2026	2041	2044	2054
DIMENSIONS	A. Overall Operating Height - Fully Raised	3167 mm	3546 mm	3584 mm	3645 mm	3721 mm
	B. Height to Hinge Pin - Fully Raised	2438 mm	2746 mm	2794 mm	2845 mm	2946 mm
	C. Overall Height to Top of ROPS	1897 mm	1786 mm	1826 mm	1974 mm	1974 mm
	D. Ground Clearance to Chassis	150 mm	152 mm	211 mm	191 mm	197 mm
	E. Overall Length with Bucket	2576 mm	2896 mm	2952 mm	3137 mm	3188 mm
	F. Overall Length without Bucket	1905 mm	2258 mm	2314 mm	2413 mm	2448 mm
	G. Wheelbase	775 mm	876 mm	932 mm	932 mm	978 mm
	H. Dump Reach at Full Height	376 mm	579 mm	574 mm	654 mm	610 mm
	I. Bucket Rollback at Ground	23°	29°	29°	28°	28°
	J. Dump Angle	46°	42°	42°	32°	34°
	K. Overall Width	909 mm	1229 mm	1346 mm	1499 mm	1544 mm
	L. Bucket Width	914 mm	1404 mm	1404 mm	1562 mm	1562 mm
	M. Clearance Circle - Rear	1097 mm	1374 mm	1484 mm	1283 mm	1506 mm
	N. Clearance Circle - Front without Bucket	833 mm	1120 mm	1102 mm	997 mm	1162 mm
	O. Clearance Circle - Front with Bucket	1473 mm	1763 mm	1758 mm	1854 mm	1892 mm
	P. Seat to Ground Height	879 mm	828 mm	853 mm	879 mm	884 mm
	Q. Rollback at Full Height	100°	99°	99°	100°	100°
	R. Dump Height	1836 mm	2146 mm	2197 mm	2242 mm	2337 mm
	S. Departure Angle	30°	26°	29°	24°	26°
	Standard Tire Size		5.70 x 12	27 x 8.5 x 15 HD	10.00 x 16.5 HD	10.00 x 16.5 HD
ENGINE	Make	Yanmar	Yanmar	Yanmar	Yanmar	Yanmar
	Model	3TNV82 - Stage 3B	3TNV88 - Stage 3B	4TNV88 - Stage 3B	4TNV88 - Stage 3B	4TNV88 - Stage 3B
	Net Power (hp) @ rpm	24 hp (17.9) @ 2400	35 hp (26) @ 2800	46 hp (34) @ 2600	47 hp (34.2) @ 2600	47 hp (34.2) @ 2600
	Displacement	1.3 L	1.6 L	2.2 L	2.2 L	2.2 L
	Maximum Torque @ rpm	86 Nm @1200	108 Nm @ 1680	145 Nm @1680	145 Nm @ 1680	145 Nm @ 1680
HYDRAULIC SYSTEM	Auxiliary Hydraulics - Standard	38 L/min	55 L/min	62 L/min	70 L/min	68.1 L/min
	High-Flow Hydraulics - Optional	N/A	N/A	N/A	N/A	106 L/min
	System Relief Pressure	145 bar	190 bar	190 bar	162 bar	197 bar
	Reservoir Capacity	27.3 L	30.3 L	30.3 L	45 L	45 L
ELECTRICAL	Battery	650 CCA	675 CCA	675 CCA	700 CCA	950 CCA
	Starter	1.7 kW	2.3 kW	2.3 kW	2.3 kW	2.3 kW
	Alternator	40-amp	40-amp	40-amp	40-amp	40-amp
CAPACITIES /WEIGHT	Rated Operating Capacity <sup>A</sup>	386 kg	476 kg	612 kg	658 kg	748 kg
	With Optional Counterweight	N/A	533 kg	669 kg	703 kg	794 kg
	Tipping Load	775 kg	953 kg	1225 kg	1315 kg	1497 kg
	Fuel Tank	29 L	39.4 L	47 L	54.1 L	57 L
	Travel Speed - Maximum	8.9 km/hr	9.5 km/hr	8.7 km/hr	10.6 km/hr	10.9 km/hr
	Operating Weight <sup>B</sup> - Approximate	1352 kg	1814 kg	2087 kg	2551 kg	2758 kg

A - Per SAE J818, SAE J732, and ISO 14397

B - Unit weight with standard bucket, 79 kg operator and full fuel tank

Mustang reserves the right to make changes in specifications at any time without notice or obligation.

2056 Series II	2076	2086
3899 mm	4115 mm	4275 mm
3086 mm	3124 mm	3157 mm
2017 mm	2057 mm	2083 mm
191 mm	203 mm	231 mm
3208 mm	3327 mm	3594 mm
2416 mm	2553 mm	2687 mm
1067 mm	1080 mm	1229 mm
578 mm	813 mm	894 mm
23°	28°	28°
43°	37°	37°
1600 mm	1753 mm	1841 mm
1676 mm	1778 mm	1880 mm
1454 mm	1676 mm	1753 mm
1111 mm	1283 mm	1372 mm
2019 mm	2083 mm	2299 mm
953 mm	1067 mm	1100 mm
88°	97°	97°
2330 mm	2375 mm	2408 mm
23°	26°	29°
12.00 x 16.5 HD	12.00 x 16.5 HD	14.00 x 16.5 HD
Yanmar	Yanmar	Yanmar
4TNNV98 - Stage 3B	4TNNV98T - Stage 3B	4TNNV98T - Stage 3B
68 hp (50.7) @ 2500	71 hp (52.7) @ 2500	71 hp (52.7) @ 2500
3.3 L	3.3 L	3.3 L
244 Nm @ 1650	279.3 Nm @ 1700	279.3 Nm @ 1700
72 L/min	82.5 L/min	82.5 L/min
114 L/min	139.7 L/min	139.7 L/min
190 bar	207 bar	207 bar
56.8 L	60.6 L	60.6 L
950 CCA	950 CCA	950 CCA
3.0 kW	3.0 kW	3.0 kW
95-amp	95-amp	95-amp
862 kg	998 kg	1179 kg
930 kg	1134 kg	1315 kg
1724 kg	1996 kg	2359 kg
56.8 L	71.9 L	91 L
19.9 km/hr	19.8 km/hr	22.4 km/hr
3039 kg	3452 kg	3964 kg

## 2012

### REFERENCE DIAGRAM

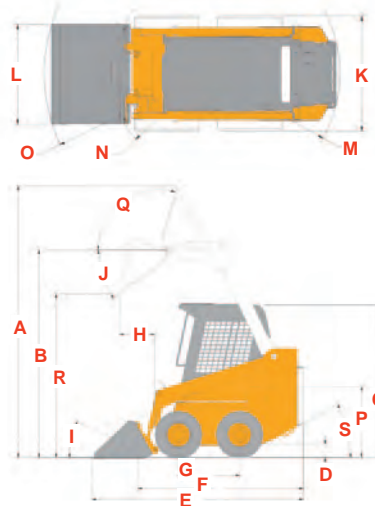

## 2026 / 2041

### REFERENCE DIAGRAM

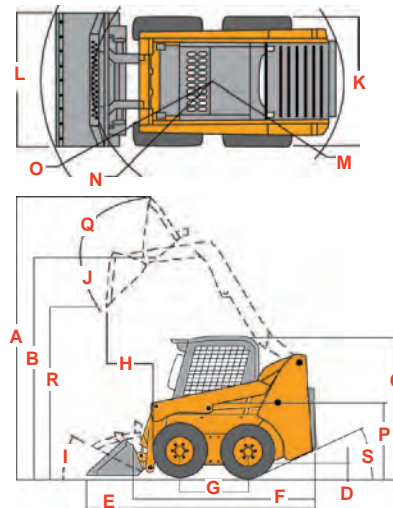

## 2044 / 2054 / 2056 SERIES II / 2076 / 2086

### REFERENCE DIAGRAM

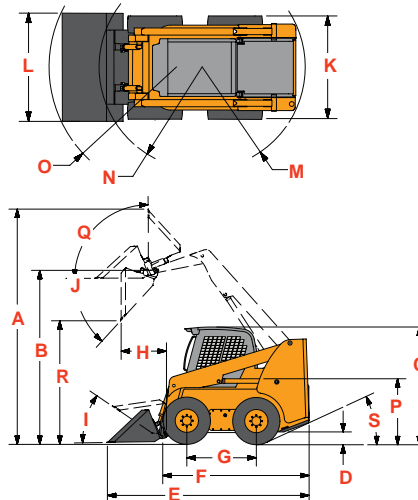

# SKID STEER LOADER FEATURES

SPECIFICATIONS	2012	2026	2041	2044	2054	2056 SERIES II	2076	2086
<b>PILOT CONTROLS</b>								
T-Bar Hand Controls	○	●	●	●	●			
Hand/Foot Controls		●	●	●	●	●	●	●
Joystick Controls						●	●	●
Dual-Hand Controls				●	●	●	●	●
<b>ENGINE</b>								
Engine Auto-Shutdown System		●	●	●	●	○	○	○
Engine Pre-heater	●	●	●	●	●	●	●	●
Turbo-charged Engine							○	○
<b>HYDRAULICS</b>								
Auxiliary Hydraulics	○	○	○	○	○	○	○	○
High-Flow Auxiliary Hydraulics					●	●	●	●
Independent Hydraulic Reservoir	○	○	○	○	○	○	○	○
<b>OPERATOR STATION</b>								
Air-Conditioning						●	●	●
Cab Enclosure	●	●	●	●	●	●	●	●
Foot and Hand Throttles	○	○	○			○	○	○
Full Instrumentation	○	○	○	○	○	○	○	○
Heating	●	●	●	●	●	●	●	●
Horn	●	●	●	●	●	●	●	●
Integral Access Plate (removable)	○	○	○	○	○	○	○	○
Operator Restraint Bar with Padded Armrests / Seat Belt	○	○	○	○	○	○	○	○
ROPS/FOPS Level II Overhead Guard w/ Integral Side Screens	○	○	○			○	○	○
Sound Reduction Package		●	●	●	●	○	○	○
Suspension Seat	●	●	●	●	●	●	○	○
Work Lights – Front and Rear	○	○	○	○	○	○	○	○
<b>PERFORMANCE</b>								
Multi-Tach™ Attachment Mounting System	○	○	○	○	○	○	○	○
Power-A-Tach® Attachment Mounting System						●	●	●
Anti-Vandalism Protection	○	○	○	○	○	○	○	○
Back-up Alarm	●	●	●	●	●	●	●	●
Brake Control (auto / manual)	○	○	○	○	○	○	○	○
Hydraglide™ Ride Control						●	○	○
Hydrostatic Drive	○	○	○	○	○	○	○	○
Lift Arm Support Device	○	○	○	○	○	○	○	○
Self-Leveling Lift Action	●	●	●	●	●	○	○	○
Two-Speed Drive						●	●	●

● OPTIONAL ○ STANDARD

## SAFETY IS NO ACCIDENT

Mustang reminds users to read and understand the operator's manual before operating any piece of equipment. Additionally, make sure all safety devices and shields are in place and functioning properly.

# ORIGINAL WORKHORSE

Mustang authorized dealers offer a full line of compact equipment, backed up by exceptional sales, service and parts support. To find your nearest authorized Mustang dealer, visit the Dealer Locator on [eu.mustangmfg.com](http://eu.mustangmfg.com).



For more information on Mustang Skid Steer Loaders and the rest of the Mustang equipment line, visit our web-site at

[eu.mustangmfg.com](http://eu.mustangmfg.com)

Your nearest MUSTANG dealer:

# MUSTANG®

Head Office: Manitou Group  
B.P. 249 - 430 rue de L'Aubinière - 44158 Ancenis Cedex - France  
Tel : 00 33 (0)2 40 09 10 11 - Fax : 00 33 (0)2 40 83 36 88