

# Ogura Electro-Hydraulic Portable Rebar Benders HBB-32HPW



## Features

- Fully compatible with high-strength reinforcing bars required by the new era construction method = SD490.
- A “repair” vendor that integrates the hydraulic pump and the workpiece.
- Correction work by “push / pull bending” on-site is possible.
- Because the tip turns freely, it is possible to respond flexibly on site.

<b>Model</b>	<b>HBB-32HPW</b>
Motor	Single-Phase, 110-115V/220-230V, 50/60Hz, 1330W Double Isulation
Bending Speed	<ul style="list-style-type: none"> <li>• 90 degrees bend</li> <li>• D32:15.0 seconds</li> <li>• D13:12.0 seconds</li> </ul>
Max. Bending Capacity	620N/mm <sup>2</sup> (63kgf/mm <sup>2</sup> ) Max.D32 Grade 60 / SD490
Weight	25.4kg
Dimensions	670mm (L)×302mm (W)×219mm (H)
Min. required height from the ground when 90 degrees bend	Push Bend: Approx. 495mm Pull Bend: Approx. 485mm
Manufactures	Ogura (Japan)
Standard Accessories	<ul style="list-style-type: none"> <li>• Wooden box</li> <li>• Hydraulic oil #46</li> <li>• Hex wrenches (3•4•5•6•8mm)</li> <li>• Spanner(14×17mm &amp; 24mm)</li> <li>• Roller</li> </ul>
Warranty	- 6 month from date of delivery against manufacturing fault. - Warranty does not cover any damage caused as a result of improper use, Abuse, modification or alteration of the product.

# OTHER INFORMATION

## HBB-32HPW

### ■ Clearance A for Push Bending

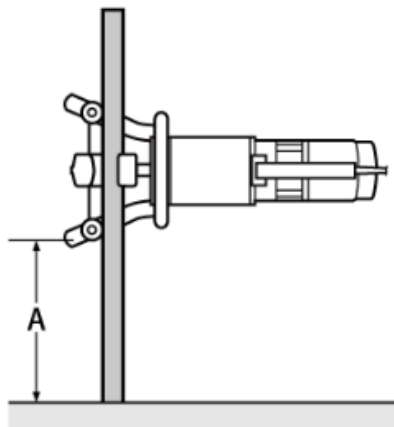

**Before Push Bending**

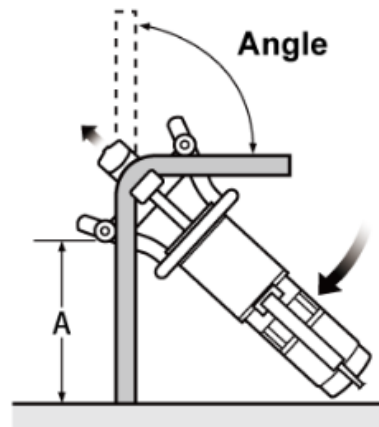

**After Push Bending**

### ■ Clearance A for Pull Bending

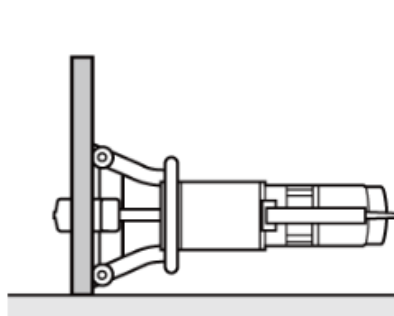

**Before Pull Bending**

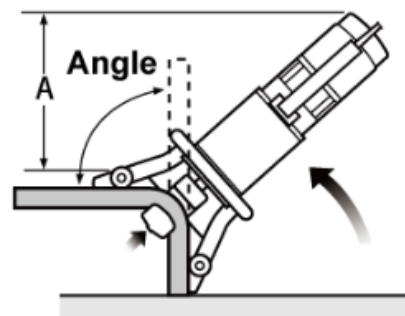

**After Pull Bending**

#### REQUIRED CLEARANCE A FOR PUSH / PULL BENDING

45 degrees  
over 180 mm / over 7.09 in

90 degrees  
over 385 mm / over 15.16 in

■ Bending Angle



(Push Bending)

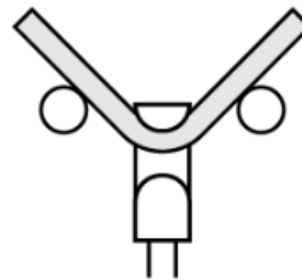

(Pull Bending)



(Push Modification Bending)

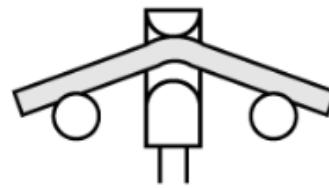

(Pull Modification Bending)

DIA. OF REBAR	MAX. CAPABLE PUSH / PULL BENDING ANGLE		MIN. REQUIRED PUSH / PULL BENDING MODIFICATION ANGLE
	WITH ROLLER	WITHOUT ROLLER	STANDARD BENDING HOOK
D13 / #4	82°	-	125°
D16 / #5	78°		130°
D19 / #6	69°		135°
D22 / #7	65°		137°
D25 / #8	65°	90°	138°
D29 / #9	-	85°	145°
D32 / #10	-	80°	147°