

## TRUCK FEATURES



### STANDARD EQUIPMENT:

- BYD Iron-Phosphate Technology
- Battery 80V 270Ah (21.6 kWh)
- AC drive
- 4-way valve
- Fork tilting
- Hook-on side-shifter
- Finger-tip control
- TFT display
- Cornering speed reduction
- OPS (Operator Presence Sensor)
- Regenerative braking system
- Load wheel brake
- Charger 80V 100A
- 2-hour charging time
- Adjustable steering wheel
- Orange seat belt with sensor

### OPTIONAL EQUIPMENT:

- 1-hour fast-charging solution
- Charger 80V 200A
- Fork camera system
- Load weight indicator
- Blue light
- Panoramic mirror
- Rear working light
- Speed reduction with mast lifted



RTR16 is the first reach truck offering from BYD and features state-of-art design with optimal driving comfort, safety and working efficiency.

BYD Reach Trucks are powered by the BYD Iron-Phosphate Technology and feature the most up-to-date Battery Management System. We also offer the longest battery-warranty in the industry, 8 years or 10,000 hours, whichever comes first.

Thanks to ultra-fast side charging with flexible battery and charger options, BYD Reach Trucks easily operate in multi-shift applications on a single battery, saving you both time and money.

## REACH TRUCK RTR16

BYD REACH TRUCK (1600kg)

CHANGE YOUR MIND  
NOT YOUR BATTERY

 Lithium |  8 YRS 10,000 HRS Battery Warranty | BYD Iron-Phosphate

## MAST SPECIFICATIONS

- h3** Lifting Height (mm)    **h2** Full Free Lift Height (mm) (Load Backrest 1070mm)    **h1** Height, Mast Fully Lowered (mm)  
**h4** Height, Mast Fully Extended (mm) (Load Backrest 1070mm)    **α** Tilt Forward    **β** Tilt Backward

Mast Specifications (mm)	h3	h2	h1	h4	α	β	Residual Capacity (kg)	
							LCD@600mm	
3-Stage Full Free Lift Mast	4500	961	2161	5746	2°	4°	1600	
	4800	1061	2261	6046	2°	4°	1600	
	5100	1161	2361	6346	2°	4°	1600	
	5550	1311	2511	6796	2°	4°	1600	
	6000	1461	2661	7246	2°	4°	1600	
	6450	1611	2811	7696	2°	4°	1600	
	6750	1761	2961	7996	2°	4°	1600	
	7200	1911	3111	8446	2°	4°	1600	
	7650	2061	3261	8896	2°	4°	1600	
	8100	2211	3411	9346	2°	4°	1600	
	8500	2296	3496	9746	2°	4°	1600	
	9500	2696	3896	10746	2°	4°	1300	

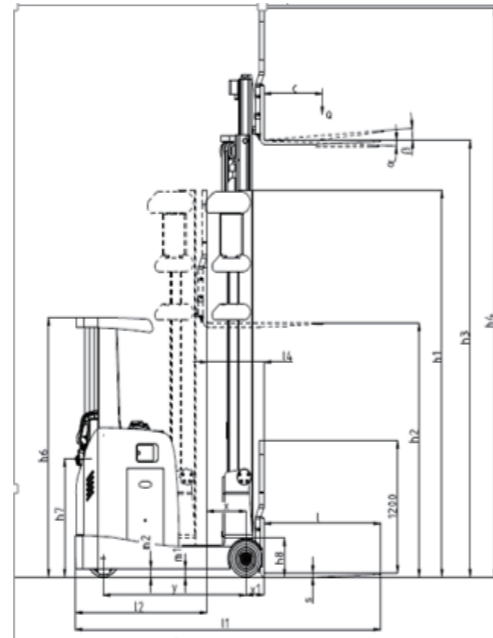
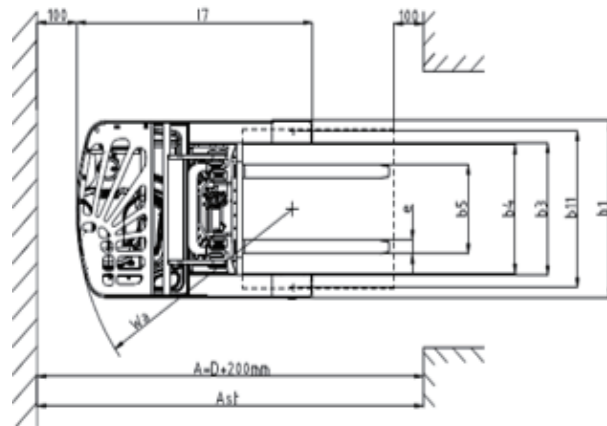

## RTR16 SPECIFICATIONS

Identification	1.1	Manufacturer				BYD
	1.2	Model				RTR16
	1.3	Drive				Electric
	1.4	Operator type				Seated
	1.5	Rated capacity	Q	kg		1600
	1.6	Load center	c	mm		600
	1.8	Load distance, center of drive axle to fork	x	mm		188/400
	1.9	Wheelbase	y	mm		1470

Weight	2.1	Net weight including battery		kg	4070		
	2.3	Axle loading, fork advanced, laden front/rear		kg	1909/2361		
	2.4	Axle loading, unladen front/rear		kg	1038/4832		
	2.5	Axle loading, fork retracted, laden front/rear		kg	2627/1643		
	Wheels, Chassis	3.1	Wheel type			PU	
3.2		Tyre size, front			Φ343×136		
3.3		Tyre size, rear			Φ340×100		
3.5		Wheels, number front rear (x=driven wheels)			1x/2		
3.7		Tread width, rear	b11	mm	1170		
Basic Dimensions	4.1	Tilt of mast/fork carriage forward/backward	α/β	(°)	2/4		
	4.2	Mast height (lowered)	h1	mm	3496		
	4.3	Free lift	h2	mm	2250		
	4.4	Lift height	h3	mm	8500		
	4.5	Extended mast height	h4	mm	9746		
	4.7	Height of overhead guard	h6	mm	2345		
	4.8	Seat height/standing height	h7	mm	1020		
	4.10	height of support arms	h8	mm	360		
	4.19	Overall length	l1	mm	2555		
	4.20	Length to face of forks	l2	mm	1355		
	4.21	Overall width	b1	mm	1270		
	4.22	Fork dimensions	s/e/l	mm	35/100/1200		
	4.23	Fork carriage ISO 2328, class/type A, B			2A		
	4.24	Fork carriage width	b3	mm	730		
	4.25	Width across forks	b5	mm	430/678		
	4.26	Width between support arms/loading areas	b4	mm	930		
	4.28	Reach distance	l4	mm	588		
	4.31	Ground clearance, under the mast	m1	mm	73		
	4.32	Ground clearance, center of wheelbase	m2	mm	80		
	4.33	Aisle width for pallets 1000×1200 crossways	Ast	mm	2848		
	4.34	Aisle width for pallets 800×1200 lengthways	Ast	mm	2904		
	4.35	Turning radius	Wa	mm	1758		
	4.37	Length across support arms	l7	mm	1930		
	Performance Data	5.1	Travel speed, with/without load		Km/h	13/13	
		5.2	Lift speed, with/without load		mm/s	380/680	
		5.3	Lowering speed, with/without load		mm/s	550/550	
		5.4	Mast reaching speed, with/without load		mm/s	180/180	
		5.4a	Mast retracting speed, with/without load		mm/s	180/180	
		5.8	Max. gradeability, with/without load		%	12/12	
		5.9	Acceleration time, with/without load (0-10m)		s	5.6/5.0	
		5.10	Service brake			Hydraulic/Mechanic	
		Motor	6.1	Drive motor rating S2 60 min.		kW	6.8/13.2
			6.2	Lift motor rating at S3 15%		kW	12/19
	6.4		Battery voltage, nominal capacity K5		V/Ah	80/270	
	6.5		Battery weight		kg	425	
	Others		8.1	Type of drive control			AC
		8.2	Operating pressure for attachments		bar	210	
8.4		Sound level at the driver's ear		dB(A)	≤75		

\*BYD reserves the right to alter and modify the design, features and technical parameters of its products at any given time and without pre-advise, as products are subject to ongoing and continuous development.