

Electric powered forklift 3.5 - 5.0 ton

TRIGO⁸⁰



Electric powered forklift 3.5 ton

Truck specifications					9FBM35T
Identification	1.1	Manufacturer			Toyota
	1.2	Model			9FBM35T
	1.3	Drive			Electric
	1.4	Operator type			driver seated
	1.5	Load capacity/rated load	Q	kg	3500
	1.6	Load centre	c	mm	500
	1.7	Load distance, centre of drive axle to fork	x	mm	440
	1.8	Wheelbase	y	mm	1735
Weight	2.1	Service weight		kg	5721
	2.2	Axle load, with load, front/rear		kg	8106 / 1115
	2.3	Axle load, without load, front/rear		kg	2709 / 3012
Tyres	3.1	Tyres: C=Cushion, SE=Super elastic, PN=Pneumatic, TW=Twin			SE
	3.2	Tyre size, front (SE)			315/45-12
	3.3	Tyre size, rear (SE)			200/50-10
	3.4	Wheels, number front/rear (x = driven wheels)			2x/2
	3.5	Track width, front	b_{10}	mm	1009
	3.6	Track width, rear	b_{11}	mm	962
Dimensions	4.1	Tilt of mast/fork carriage forward/backward	α/β	deg	4.25/8
	4.2	Height, mast lowered	h_1	mm	2395
	4.3	Free lift	h_2	mm	125
	4.4	Lift	h_3	mm	3300
	4.5	Lift height	h_{23}	mm	3345
	4.6	Height, mast extended	h_4	mm	4035
	4.7	Height of overhead guard (cab)	h_5	mm	2215
	4.8	Seat height/stand height	h_7	mm	1230
	4.9	Coupling height	h_{10}	mm	460
	4.10	Overall length	l_1	mm	3488
	4.11	Length to face of forks	l_2	mm	2488
	4.12	Overall width	b_1	mm	1299
	4.13	Fork dimensions	s/e/l	mm	45/125/1000
	4.14	Fork carriage DIN 15 173, class/type A, B			IIIA
	4.15	Fork-carriage width	b_3	mm	1070
4.16	Ground clearance, with load, below mast	m_1	mm	95	
4.17	Ground clearance, centre of wheelbase	m_2	mm	132	
4.18	Aisle width for pallets 1000x1200 crossways	A_{st}	mm	3841	
4.19	Aisle width for pallets 800x1200 lengthways	A_{st}	mm	4040	
4.20	Turning radius	W_a	mm	2200	
4.21	Internal turning radius	b_{13}	mm	545	
Performance data	5.1	Travel speed, with/without load, Standard Performance		km/h	16/16 19/20
	5.2	Lift speed, with/without load, Standard Performance		m/s	N.A. 0.37/0.55
	5.3	Lowering speed, with/without load		m/s	0.56/0.45
	5.4	Drawbar pull, with/without load, Standard Performance		N	8000 10000
	5.5	Max. drawbar pull, with/without load, Standard Performance		N	18000 20000
	5.6	Gradeability, with/without load, Standard Performance		%	10/18 15/26
	5.7	Max. gradeability, with/without load, Standard Performance		%	17/29 20/29
	5.8	Acceleration time, with/without load, Standard Performance		s	5.3/5.0 4.9/4.3
	5.9	Service brake			mech./hydr.
Electric motor	6.1	Drive motor rating S2 60 min, Standard Performance		kW	16.1 21.4
	6.2	Lift motor rating S3 15%, Standard Performance		kW	17.3 16.7
	6.3	Battery acc. to DIN 43 531/35/36 A, B, C, no			DIN 43536 A
	6.4	Battery voltage, nominal capacity K_5		V/Ah	80/700
	6.5	Battery weight		kg	1863
	6.6	Energy consumption acc. to EN16796:2016, Standard Performance		kWh/h	N.A. 7.6
Other	8.1	Type of drive control			AC
	8.2	Operating pressure for attachments		bar	160
	8.3	Oil volume for attachments		l/min	40
	8.4	Sound level at the driver's ear according to EN 12 053		dB(A)	64.9

All data are based on table configuration. Other configurations may give other values.

Products and specifications are subject to change without notice.

Truck performance and dimensions are nominal and subject to tolerances.

Electric powered forklift 4.0 - 5.0 ton

Truck specifications					8FBMT40	8FBMT45	8FBMT50
Identification	1.1	Manufacturer			Toyota	Toyota	Toyota
	1.2	Model			8FBMT40	8FBMT45	8FBMT50
	1.3	Drive			Electric	Electric	Electric
	1.4	Operator type			Rider seated	Rider seated	Rider seated
	1.5	Load capacity/rated load	Q	kg	4000	4500	4990
	1.6	Load centre	c	mm	500	500	600
	1.7	Load distance, centre of drive axle to fork	x	mm	518	518	528
	1.8	Wheelbase	y	mm	2030	2030	2030
Weight	2.1	Service weight		kg	6556	7086	7721
	2.2	Axle load, with load, front/rear		kg	9555 / 1102	10261 / 1325	11316 / 1406
	2.3	Axle load, without load, front/rear		kg	3558 / 3099	3515 / 3572	3548 / 4173
Tyres	3.1	Tyre: C = Cushion, SE = Super elastic, PN = Pneumatic, TW = Twin			SE	SE	SE
	3.2	Tyre size, front			250-15	250-15	28x12,5-15
	3.3	Tyre size, rear			23x9-10	23x9-10	23x9-10
	3.4	Wheels, number front/rear (x = driven wheels)			2 / 2	2 / 2	2 / 2
	3.5	Track width, front	b ₁₀	mm	1119	1119	1145
	3.6	Track width, rear	b ₁₁	mm	1113	1113	1113
Dimensions	4.1	Tilt of mast/fork carriage forward/backward	α/β	deg	5/10	5/10	5/10
	4.2	Height, mast lowered	h ₁	mm	2500	2500	2500
	4.3	Free lift	h ₂	mm	130	130	140
	4.4	Lift	h ₃	mm	3300	3300	3300
	4.5	Lift height	h ₂₃	mm	3350	3350	3360
	4.6	Height, mast extended	h ₄	mm	4156	4156	4156
	4.7	Height of overhead guard (cab)	h ₆	mm	2360	2360	2360
	4.8	Seat height/stand height	h ₇	mm	1277	1277	1277
	4.9	Coupling height	h ₁₀	mm	550	550	550
	4.10	Overall length	l ₁	mm	3907	3947	4272
	4.11	Length to face of forks	l ₂	mm	2907	2947	3072
	4.12	Overall width	b ₁	mm	1345	1345	1440
	4.13	Fork dimensions	s/e/l	mm	50/150/1000	50/150/1000	60/150/1200
	4.14	Fork carriage DIN 15 173, class/type A, B			IIIA	IIIA	IIIA
4.15	Fork-carriage width	b ₃	mm	1170	1170	1170	
4.16	Ground clearance, with load, below mast	m ₁	mm	150	150	150	
4.17	Ground clearance, centre of wheelbase	m ₂	mm	152	152	152	
4.18	Aisle width for pallets 1000x1200 crossways	A _{st}	mm	4260	4276	4412	
4.19	Aisle width for pallets 800x1200 lengthways	A _{st}	mm	4460	4476	4612	
4.20	Turning radius	W _a	mm	2543	2558	2686	
4.21	Internal turning radius	b ₁₃	mm	685	685	685	
Performance data	5.1	Travel speed, with/without load		km/h	18/18	18/18	18/18
	5.2	Lift speed, with/without load		m/s	0.35/0.46	0.35/0.46	0.33/0.46
	5.3	Lowering speed, with/without load		m/s	0.55/0.46	0.55/0.46	0.55/0.46
	5.4	Drawbar pull, with/without load		N	12420	12420	12420
	5.5	Max. drawbar pull, with/without load		N	22000	22000	22000
	5.6	Gradeability, with/without load		%	11.3/17	9.5/16.8	8.8/15.8
	5.7	Max. gradeability, with/without load		%	15/25	14/24	13/23
	5.8	Acceleration time, with/without load		s	5.1/4.5	5.2/4.5	5.3/4.6
	5.9	Service brake			Mechanical/hydraulic	Mechanical/hydraulic	Mechanical/hydraulic
Electric motor	6.1	Drive motor rating S2 60 min		kW	25.2	25.2	25.2
	6.2	Lift motor rating S3 15%		kW	25.5	25.5	25.5
	6.3	Battery acc. to DIN 43 531/35/36 A, B, C, no			43536	43536	43536
	6.4	Battery voltage, nominal capacity K ₅		V/Ah	80 / 840	80 / 840	80 / 840
	6.5	Battery weight		kg	2178	2178	2178
Other	8.1	Type of drive control			AC	AC	AC
	8.2	Operating pressure for attachments		bar	160-180	160-180	160-180
	8.3	Oil volume for attachments		l/min	70	70	70
	8.4	Sound level at the driver's ear according to EN 12 053		dB(A)	68	68	68

All data are based on table configuration. Other configurations may give other values.
Truck performance and dimensions are nominal and subject to tolerances.
Products and specifications are subject to change without notice.

Mast dimensions and rated capacities

Model			V								FV/FW				FSV/FSW								
8FBMT40, 8FBMT45	Lift height	h_{23}	3050	3350	3750	4050	4550	5050	5550	—	3050	3350	3750	4050	—	4200	—	4450	4750	5050	5550	6050	6550
	Lift	h_3	3000	3300	3700	4000	4500	5000	5500	—	3000	3300	3700	4000	—	4150	—	4400	4700	5000	5500	6000	6500
	Height, mast lowered	h_1	2360	2500	2750	2880	3130	3380	3630	—	2360	2500	2750	2880	—	2200	—	2360	2440	2500	2750	2880	3130
	Height, mast extended ¹⁾	h_4	3856	4156	4560	4856	5356	5856	6356	—	3890	4190	4590	4890	—	5040	—	5290	5590	5890	6390	6890	7390
	Height, mast extended ²⁾	h_4	4200	4500	4900	5200	5700	6200	6700	—	4200	4500	4900	5200	—	5350	—	5600	5900	6200	6700	7200	7700
	Free lift, without load backrest	h_2	80	80	80	80	80	80	80	—	1470	1610	1860	1990	—	1310	—	1470	1550	1610	1860	1990	2240
	Free lift, with load backrest	h_2	80	80	80	80	80	80	80	—	1160	1240	1300	1550	—	1000	—	1160	1240	1300	1550	1680	1930
8FBMT50	Lift height	h_{23}	3060	3360	3760	4060	4560	5060	5560	2860	—	3360	3760	4060	4060	—	4360	—	4760	5060	5560	6060	6560
	Lift	h_3	3000	3300	3700	4000	4500	5000	5500	2800	—	3300	3700	4000	4000	—	4300	—	4700	5000	5500	6000	6500
	Height, mast lowered	h_1	2360	2500	2750	2880	3130	3380	3630	2360	—	2630	2880	3130	2200	—	2360	—	2500	2630	2880	3130	3380
	Height, mast extended ¹⁾	h_4	3956	4156	4560	4856	5356	5856	6356	3690	—	4190	4590	4890	4890	—	5190	—	5590	5890	6390	6890	7390
	Height, mast extended ²⁾	h_4	4200	4500	4900	5200	5700	6200	6700	4000	—	4500	4900	5200	5200	—	5500	—	5900	6200	6700	7200	7700
	Free lift, without load backrest	h_2	80	80	80	80	80	80	80	1470	—	1740	1990	2240	1310	—	1470	—	1610	1740	1990	2240	2490
	Free lift, with load backrest	h_2	80	80	80	80	80	80	80	1160	—	1430	1680	1930	1000	—	1160	—	1300	1430	1680	1930	2180

1) Without load backrest.

2) With load backrest; Height of standard load backrest is 1200 mm.

Pneumatic shaped cushion tyre		V								FV/FW				FSV/FSW									
8FBMT40	Tilt range, forward	deg	5	5	5	5	5	5	5	—	5	5	5	5	—	5	—	5	5	5	5	5	5
	Tilt range, backward	deg	10(6)	10(6)	10(6)	10(6)	6	6	6	—	10(6)	10(6)	10(6)	10(6)	—	6	—	6	6	6	6	6	6
	Load capacity at 500 mm LC	kg	4000	4000	4000	4000	4000	4000	3950	—	4000	4000	4000	4000	—	4000	—	4000	4000	4000	3850	3710	3400
8FBMT45	Tilt range, forward	deg	5	5	5	5	5	5	5	—	5	5	5	5	—	5	—	5	5	5	5	5	5
	Tilt range, backward	deg	10(6)	10(6)	10(6)	10(6)	6	6	6	—	10(6)	10(6)	10(6)	10(6)	—	6	—	6	6	6	6	6	6
	Load capacity at 500 mm LC	kg	4500	4500	4500	4500	4500	4500	4450	—	4500	4500	4500	4500	—	4500	—	4500	4500	4470	4340	4210	3650
8FBMT50	Tilt range, forward	deg	5	5	5	5	5	5	5	—	5	5	5	5	—	5	—	5	5	5	5	5	5
	Tilt range, backward	deg	10(6)	10(6)	10(6)	10(6)	6	6	6	10(6)	—	10(6)	10(6)	10(6)	6	—	6	—	6	6	6	6	6
	Load capacity at 600 mm LC	Kg	4990	4990	4990	4990	4990	4990	4950	4990	—	4990	4990	4990	4990	—	4990	—	4970	4890	4750	4610	3850

Data in () are for when "Cabin Series" or front windshield is selected.

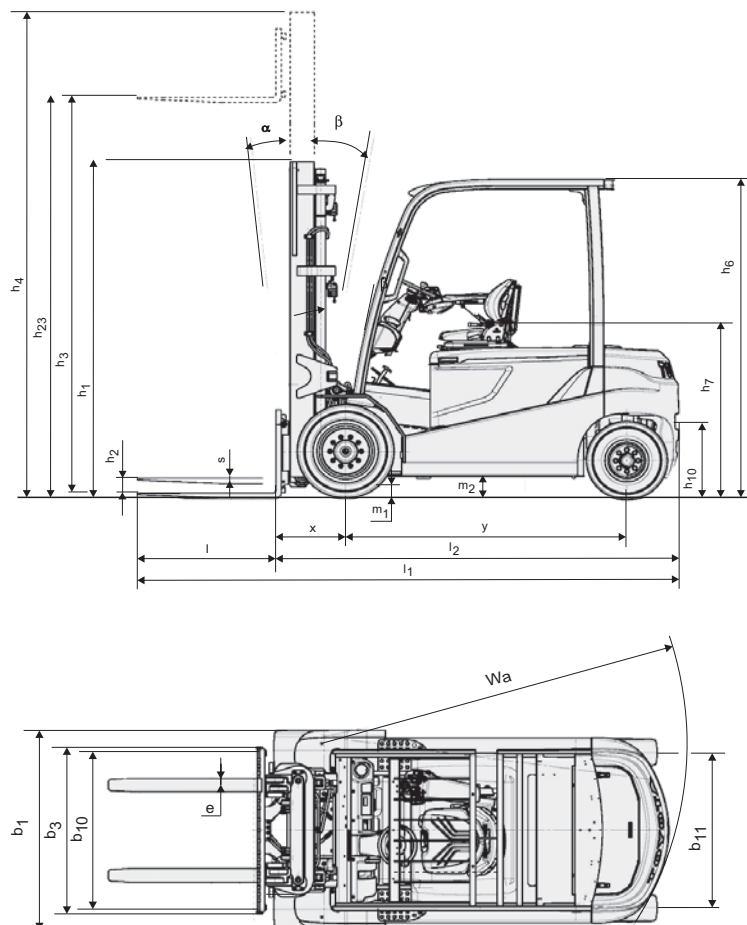

Standard equipments:

- Toyota SAS (System of Active Stability)
- Toyota AC power system
- Operator presence sensing system (OPS)
- Toyota ORS seat (Operator Restraint System)
- Seat mounted hydraulic minilevers
- Wide visible mast (MFH:3300)
- Long forks [length: 1000 mm (9FBMT35, 8FBMT40-45), 1200 mm (8FBMT50)]
- Long forkbar [length: 1070 mm (9FBMT35, 8FBMT40-45), 1170 mm (8FBMT40-50)]
- Load backrest (height: 1200 mm)
- 3 way valves
- Wet disc brakes
- Wide brake pedal
- Pneumatic shaped cushion tyres
- Full hydraulic power steering
- Digital Multifunction Display with wheel indicator
- Memory tilt steering column
- Emergency stop button in armrest
- Assist grip
- Automatic parking brake(9FBMT35)
- Full floating driver compartment(9FBMT35)
- Shockless landing lift(9FBMT35)