

# 658C WHEEL LOADER



**WORLD CLASS  
LEGACY TECHNOLOGY**

Engine Gross Power	225 hp / 168 kW
Operating Weight	17000 kg for 3 Cum GP Bucket
Rated Payload	5000 kg

**Shandong SEM Machinery Co., Ltd  
A Caterpillar Company**

**SEM**, formerly the Shandong Engineering and Machinery Company founded in 1958, was reformed as a shareholding company in 2003. Located in Qingzhou City, east of Shandong province, the factory is connected with major highways. With an area of 510000 squared meters and a total employee strength of 2000, SEM is capable of producing more than 15000 wheel loaders annually, targeting an annual production of 35000 units by the year 2015.

Since SEM's reformation, the company has adopted advanced management techniques to accelerate its reform and leverage production quality. From the United States, Japan and South Korea, SEM has brought in a great amount of high-graded and world class processing equipment to enhance productivity and capacity. In addition, the Six Sigma methodology was introduced to SEM by Caterpillar. All of the above have accelerated SEM's internationalization process.

In 2005, SEM successfully joined Caterpillar. With the adoption of Caterpillar's advanced management methodology and the technical support from the Caterpillar China Research and Development Center (CRDC) in Qingdao, SEM released the new 600 series wheel loaders in September 2007. The successful launch of the new wheel loaders has positioned SEM at the forefront of the wheel loader industry in China, and consolidates SEM's determination towards globalization.

Currently, SEM's products have been sold in more than 80 countries and regions. In the next 3 years, SEM will continue to expand its global service network in order to provide its worldwide customers with zero-delay service and parts support.

**Gmmco**, established in 1967, has been engaged in the sales and support of construction & mining equipment as well as engine power systems and has been associated with Caterpillar for the last 25 years. With SEM becoming a part of Caterpillar, Gmmco has also started the sales and support of SEM machines from November 2009.



# SEM 658C SPECIFICATIONS

## MAIN SPECIFICATIONS

Rated Load Capacity	5000 kg
Operating Weight	17000 kg
Bucket Capacities	3.0 - 4.5 m <sup>3</sup>
Max. Grade Ability	38°
Overall Dimension L x W x H (mm)	8176 x 3068 x 3440

## ENGINE

Rated Gross Power	225 hp / 168kW @ 2200 RPM
Model	Perkins 1106D
Bore	105 mm
Stroke	127 mm
Displacement	6.6 L
Peak Torque	99.60 Kgm / 986 N.m

## OPERATING SPECIFICATIONS

Max. Rim Pull	15704 kgf / 154 kN
Breakout Force	17131 kgf / 168 kN
Static Tipping Load Full Turn	10300 kg / 101 kN

## HYDRAULIC SYSTEM PILOT CONTROL

Pump Displacement - Implement Pump	97 mL/rev
System Pressure Setting	19 Mpa
Hydraulic Cycle Time:	
Raise	5.49 s
Dump	0.9 s
Lower (Empty, Float Down)	3.79 s
Total	10.2 s

## STEERING

Steering Angle Left/Right	38°
Minimum Turning Radius Over Rear Tire	6159 mm
Minimum Turning Radius Over Bucket	6930 mm

## AXLE

Brand	SEM S128
Front	Fixed with wet brake
Rear	Trunnion mounted axle with wet brake

Maximum Single-Wheel Rise and Fall	Oscillating ± 12°
------------------------------------	-------------------

## BRAKE SYSTEM

Service Brake	In board wet brake
Parking Brake	Drum type shoe brake, Spring applied & Air released

## TRANSMISSION

SEM 160A

Type	Countershaft, Power shift
Travel Speed:	
Forward 1	6.9 km/hr
Forward 2	12.4 km/hr
Forward 3	21.8 km/hr
Forward 4	34 km/hr
Reverse 1	6.9 km/hr
Reverse 2	12.4 km/hr
Reverse 3	21.8 km/hr

## SERVICE REFILL CAPACITIES

Fuel Tank	290 L
Cooling System	50 L
Engine Lubricating Oil	23 L
Oil for Converter and Gear Box	60 L
Differentials and Final Drives:	
Front	40 L
Rear	35 L
Hydraulic Tank	230 L

## TIRES

Size	23.5 - 25
Type	Bias
Layer	16
Textured Type	L3/E3
Air Pressure	Front 392 kPa / Rear 342 kPa

Arrangement Drawing

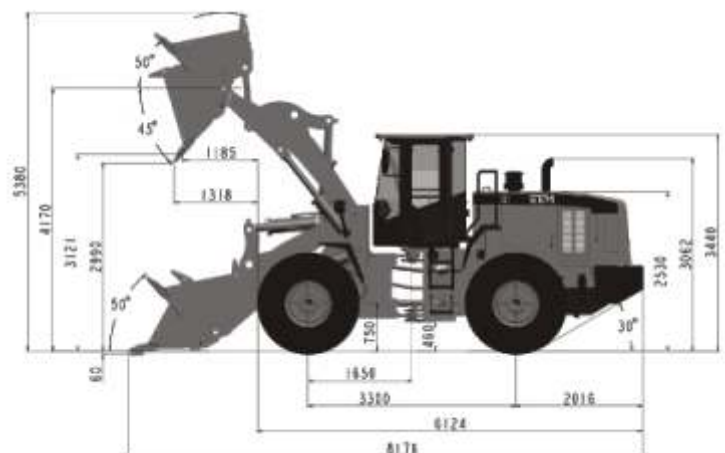

Design and specifications are subject to change without notice  
The illustrations may not show the current version of the machine

Gmmco is a part of the CK Birla group of companies, a multi-faceted business house and a household name in business and social service in India.

The \$1.6 billion CK Birla Group, with human resources of over 20000 employees worldwide, manages operations that cut across industry verticals and has a prominent presence in various industries like Cement, Auto Components, Automotive Industry, Paper, Building Materials, ITeS, Consumer Durables, Consultancy, Heavy Engineering Equipment, Hospitals, Schools, Technical Education and scientific research and development are important components of our philanthropic exercises.

Gmmco as an entity has made major strides over the last four decades to grow into a INR 1800 Crore Company with over 1600 employees operating out of over a 100 establishments today including 75 full fledged branches.

## Gmmco Network



In line with the Policy of continuous product development, we reserve the right to change specifications without notice. Featured machine in photos may include additional equipment.

### Gmmco Limited

No 6, G.S.T. Road, St. Thomas Mount, Chennai - 600 016.  
 Phone: (044) 3068 6000 / 6499 Fax: (044) 3068 6360  
 Toll-Free No: 1800 425 2546 Email: sales@gmmcoindia.com

Shandong SEM Machinery Co., Ltd.,  
 Qingzhou City, Shandong Province,  
 China. Zip 262500.

[www.gmmco.in](http://www.gmmco.in)